

PaX-i3D Smart™

User Manual

Model : PHT-30LFO
Version : 1.33

- English



Full version



vatech

innovation **i**nside

"i" stands for 'innovation', one of the core values of VATECH, which aims to expand accessibility of medical solutions to more people.

Notice

Thank you for purchasing the **PaX-i3D Smart™** extra-oral imaging system.

The **PaX-i3D Smart™** is an advanced digital dental diagnostic system that incorporates PANO, CEPH, and CBCT imaging capabilities into a single system.

This manual describes how to operate the **PaX-i3D Smart™** system. It is recommended that you thoroughly familiarize yourself with this manual in order to make the most effective use of this equipment.

Observe all cautions, safety messages and warnings which appear in this manual.

Due to a constant technological improvement, the manual may not contain the most updated information, subjecting to change without prior notice to the persons concerned. For further information not covered in this manual, please contact us at:

VATECH Co., Ltd.

Phone: +82-1588-9510

E-mail: gcs@vatech.co.kr

This document is originally written in English.

The PaX-i3D Smart™ is referred to as Equipment in this manual.

Manual Name: PaX-i3D Smart™ (Model: PHT- 30LFO) User Manual

Version: 1.33

Publication Date: 2018-05

Table of Contents

| | |
|--|-----------|
| 1. General Information | 2 |
| 1.1 Manufacturer's Liability | 2 |
| 1.2 Owner and Operator's Obligations | 2 |
| 1.3 Conventions in this Manual | 3 |
| 1.4 Marks and Symbols | 4 |
| 2. Warnings and Precautions | 6 |
| 2.1 General Safety Precautions | 6 |
| 2.2 Electricity-related Safety Precautions | 9 |
| 2.3 Radiation Safety | 11 |
| 2.4 Warnings | 12 |
| 3. Imaging System Overview | 18 |
| 3.1 Introduction | 18 |
| 3.2 Imaging System Configuration | 20 |
| 3.3 Equipment Overview | 22 |
| 4. Imaging Software Overview | 30 |
| 4.1 PC Specifications | 30 |
| 4.2 EasyDent / EzDent-i | 32 |
| 4.3 Console Software | 33 |
| 5. Getting Started | 40 |
| 5.1 Turning On Equipment | 40 |
| 5.2 Running the Image Viewer | 42 |
| 5.3 Initiating the Console Software | 48 |
| 6. Acquiring PANO images | 52 |
| 6.1 Setting Exposure Parameters | 57 |
| 6.2 Patient Positioning | 61 |
| 6.3 X-ray Exposure | 76 |
| 6.4 Finishing Scan | 77 |
| 6.5 Confirming Image | 77 |

Table of Contents

| | |
|--|------------|
| 7. Acquiring CEPH images | 80 |
| 7.1 Setting Exposure Parameters | 82 |
| 7.2 Patient Positioning..... | 85 |
| 7.3 X-ray Exposure..... | 96 |
| 7.4 Finishing Scan..... | 97 |
| 7.5 Confirming Image | 97 |
| 8. Acquiring CBCT Images | 100 |
| 8.1 Setting Exposure Parameters | 100 |
| 8.2 Patient Positioning..... | 103 |
| 8.3 X-ray Exposure..... | 108 |
| 8.4 Finishing Scan..... | 110 |
| 8.5 Confirming Image | 110 |
| 9. Troubleshooting | 112 |
| 10. Cleaning and Maintenance..... | 116 |
| 10.1 Cleaning..... | 116 |
| 10.2 Maintenance | 117 |
| 11. Disposing of the Unit..... | 120 |
| 12. Technical Specifications | 122 |
| 12.1 Mechanical Specifications | 122 |
| 12.2 Technical Specifications | 127 |
| 12.3 Electrical Specifications | 131 |
| 12.4 Environmental Specifications | 131 |
| 13. Appendices | 134 |
| 13.1 Recommended X-ray Exposure Table | 134 |
| 13.2 X-ray Dose Data..... | 137 |
| 13.3 Electromagnetic Compatibility (EMC) Information | 142 |
| 13.4 Acquiring image for the pediatric dental patient..... | 147 |
| 13.5 Abbreviations | 150 |

1

General Information

- 1.1 Manufacturer's Liability2
- 1.2 Owner and Operator's Obligations....2
- 1.3 Conventions in this Manual.....3
- 1.4 Marks and Symbols4

1. General Information

1.1 Manufacturer's Liability

The manufacturers and/or retailers of this equipment assume responsibility for the safe and normal operation of this product only when:

- The equipment has been installed by a VATECH authorized technician.
- The equipment has been installed in accordance with all of the cautions and conditions for installation.
- Genuine VATECH approved equipment and components have been used at all times.
- All maintenance and repairs have been performed by a VATECH authorized agent.
- The equipment has been used normally in accordance with the user's manual.
- The equipment damage or malfunction is not the result of an error on the part of the owner or operator.

1.2 Owner and Operator's Obligations







- The owner of this equipment shall perform constancy tests at regular intervals in order to ensure patient and operator safety. These tests must be performed in accordance with local X-ray safety regulations.
- The owner of this equipment shall perform regular inspection and maintenance of the mechanical and electrical components in this equipment to ensure safe and consistent operation (IEC 60601-1). The owner of this equipment shall ensure inspection and cleaning works are performed in accordance with the maintenance schedule outlined in **Chapter 8 Cleaning and Maintenance**.

1. General Information

1.3 Conventions in this Manual

















The following symbols are used throughout this manual. Make sure that you fully understand each symbol and follow the instructions which accompany it.

To prevent personal injury and/or damage to the equipment, please observe all warnings and safety information included in this document.

| | | |
|---|-------------------|--|
|  | WARNING | Indicates information that should be followed with the utmost care. Failure to comply with a warning may result in severe damage to the equipment or physical injury to the operator and/or patient. |
|  | CAUTION | Indicates a situation that demands prompt and careful action, a specific remedy, or emergency attention. |
|  | X-ray | Indicates a possible danger of exposure to radiation. |
|  | IMPORTANT | Indicates a situation or action that could potentially cause problems to the equipment and/or its operation. |
|  | NOTE | Emphasizes important information or provide useful tips and hints. |
|  | SINGLE USE | Indicates a component which must be replaced for each new patient. |



1. General Information

1.4 Marks and Symbols

| Symbols | Description | Location |
|---|--|-----------------------------|
|  | Alternate current | - |
|  | Attention: consult accompanying documents | Label |
|  | Dangerous voltage | Power board |
|  | Protective earth (Ground) | Power board |
|  | Off (power: disconnect from the main switch) | Main switch |
|  | On (power: connect to the main switch) | Main switch |
|  | IEC60601-1 Degree of Protection from Electric Shock TYPE B Equipment | Label |
|  | Radiation hazard | Label |
|  | EC representative | Label |
|  | The CE symbol indicates that this product complies with the European Directive for Medical Devices 93/42/EEC as amended by 2007/47/EC as a class IIb device. | Label |
|  | The symbol indicates that this equipment received the CSA certification mark in accordance with CAN/CSA C22.2 No.601.1 regulations. | Label |
|  | Address where the equipment was manufactured | Label |
|  | This symbol indicates that electrical and electronic equipment must not be disposed of as unsorted municipal waste and must be collected separately | Label |
|  | This symbol warns ESD hazard. | MCU board /Board package |
|  | This symbol indicates that this equipment is classified as a CLASS 1 LASER PRODUCT in accordance with IEC 60825-1 ED.1 regulations. | Label |
|  | Date of manufacture | Label |
|  | Refer to Instruction manual | Label |

1. General Information

1.4 Marks and Symbols

| Symbols | Description | Location |
|---|--|----------|
|  | Caution: Federal law restricts this device to sale by or on the order of a licensed healthcare practitioner. | Label |
|  | Indicates the manufacturer's serial number so that the specific equipment can be identified. | Label |

1. General Information

1.5 Label Locations

The label is attached to the right side of the equipment and it consists of 5 parts as below.

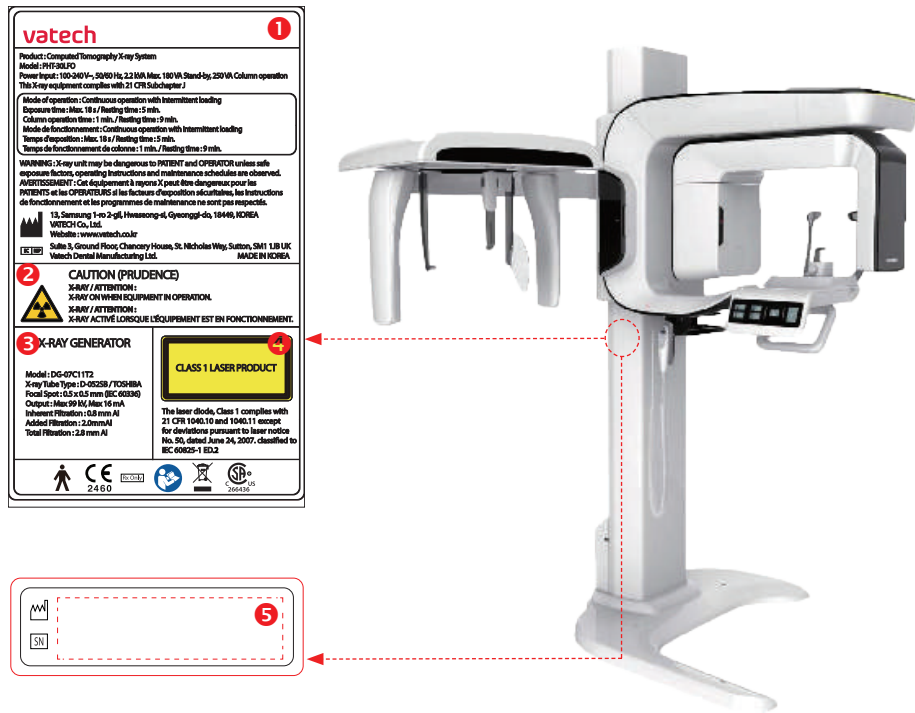

| No. | Item |
|-----|---|
| 1 | Main Label |
| 2 | CAUTION Label - X-ray / Attention: X-ray on when equipment in operation. |
| 3 | X-RAY GENERATOR Label |
| 4 | CLASS 1 LASER PRODUCT Label |
| 5 | Manufacturer Label - The date of manufacture / Serial Number |

2 | Warnings and Precautions

| | | |
|-----|---|----|
| 2.1 | General Safety Precautions..... | 6 |
| 2.2 | Electricity-related Safety Precautions | 9 |
| 2.3 | Radiation Safety..... | 11 |
| 2.4 | Warnings..... | 12 |

2. Warnings and Precautions



Be sure to strictly observe all warnings and safety instructions included in this manual.

2.1 General Safety Precautions

Operator qualifications

This equipment may only be operated by personnel fully trained in its operation.

- To operate this equipment, all operators must:
 - have read and understood the user's manual
 - be familiar with the fundamental structure and functions of this equipment
 - be able to recognize irregularities in the operation of this equipment and implement appropriate measures to remedy such irregularities.

General safety precautions

- Follow the instructions specified in this manual to ensure the safety of both the patient and the operator.
- The operator must maintain visual contact with the patient at all times during imaging.
- Do not open or remove the cover panels on this equipment. Always have a trained and authorized service technician carry out inspection and maintenance of this equipment.
- Do not place foreign objects on this equipment at any time.
- Do not place any objects within this equipment's field of operation.
- Do not push or pull the equipment. If equipment overbalances, resulting in the risk of physical injuries or property damage.
- Operators must ask the patient to remain still until the equipment arm has stopped moving and the reset motion is complete.

2. Warnings and Precautions

- Observe all local fire regulations. Always keep a fire extinguisher near the equipment.
- The operator of this equipment must be familiar with this equipment's emergency protocols.
- Ensure that this equipment is kept away from water, moisture, or foreign substances at all times.
- If this product is exposed to water, moisture, or a foreign substance, immediately turn off all power to the equipment and contact your VATECH technical support representative.
- Immediately cease all operation of this equipment if there are signs of oil leakage and contact you VATECH technical support representative.

Ventilation

- Do not obstruct the equipment's ventilation for air opening. Improper ventilation could result in the equipment overheating due to a lack of air circulation.
- Do not spray any type of liquid or aerosol on this equipment as this may penetrate the system and damage the electrical and mechanical components inside.
- Always leave a sufficient amount of space around the PC to allow for proper ventilation.

Hygiene



Always disconnect the equipment from the power outlet when cleaning the surfaces of the equipment.

- All removable patient support components (bite block, chin support, temple supports) can be cleaned using alcohol-based cleaning solutions.
- Patient support handles can be cleaned using alcohol-based cleaning solutions.
- Other surfaces of the equipment can be cleaned using a soft cloth dampened with a mild cleaning solution.

2. Warnings and Precautions

- New hygiene cover must be provided for each new patient to prevent the transmission of communicable disease.



Do not use aerosol or spray cleaning agents directly on the surface of the equipment.

Condensation

- Extreme fluctuations in temperature may cause condensation to develop inside the equipment. Do not turn on the equipment until it has reached room temperature.

Cooling

- Allow the proper amount of cool down time (for the X-ray tube to cool down) to elapse between each image acquisition.
 - Mode of operation: Continuous operation with intermittent loading.
 - Exposure time: Max. 18 s / Resting time: 5 min.
 - Column operation time: 1 min / Resting time: 9 min
- If the temperature inside the tube head reaches 60 °C, X-ray exposure will cease and an error message will be displayed. Normal X-ray capabilities will resume after the generator reaches 58 °C (136.4 °F).
- If the fan (optional) is installed, it operates automatically when the temperature surrounding the tube head reaches the pre-defined level: 40 °C (104 °F). The set point temperature is configurable.

Turning the equipment on / adjusting the height of the equipment

- Do not position the patient in the equipment while it is initiating as the patient could be injured if the equipment malfunctions.
 - Ensure that the patient is kept clear of the mechanism while adjusting the height of the equipment.
-

2. Warnings and Precautions

Emergency stop

- If a problem occurs during image acquisition, press the red emergency stop button to immediately stop all moving parts and cut off all power to the equipment.

Trouble-free operation

- Never use this equipment in an environment that is susceptible to explosion.
- Always operate the equipment within a temperature range of 10 °C to 35 °C (50 °F to 95 °F) for the safe operation. Image quality may deteriorate if the equipment is operated outside of this range.
- Always allow the equipment sufficient time to warm up (while switched on) if it has been exposed to temperatures of below 10 °C (50 °F).
- Only perform X-rays of patients if system is in full working order.
- Always ensure that equipment movement is not obstructed by the patient's clothing, medical device (such as a wheelchair), or the patient themselves.
- Do not leave the patient unattended around the equipment.
- Remove all radio-controlled devices, mobile phones, etc. from the X-ray room prior to image acquisition as these objects may cause the equipment to malfunction.

Modifying the equipment

- Modifying the equipment in any way which may affect the safety of the operator, patient or other persons is prohibited by law.
- No part of this equipment is serviceable by the user. All maintenance and repair of this equipment must be performed by a qualified service technician.
- This product may only be operated with original VATECH accessories or third-party accessories expressly approved by VATECH.

2.2 Electricity-related Safety Precautions

- Check the status of the power source, PC and cables prior to operating the equipment.
- Ensure that the on/off switch is set to off when the equipment is not in use.

2. Warnings and Precautions

- Always disconnect the power supply before cleaning the equipment.
- Always keep electrical cords away from hot appliances or radiators.
- DO NOT place the PC or peripheral equipment connected to the PC in the immediate vicinity of the patient.
- The equipment and PC should be connected to a common protective earth.
- Never overload the equipment's circuit by sharing it with too many appliances.
- Use the same power circuit for the PC and the equipment.

Combining this equipment with other devices

- Do not connect this equipment to devices which are not part of the system.
- Do not connect this equipment to a Multiple Portable Socket-Outlet (MPSO) or extension cord.

Electromagnetic compatibility

- This equipment complies with IEC standard 60601-1-2.

Medical electrical equipment is subject to special EMC preventive measures. It must be installed and operated as specified in the **Installation Requirements** document.

If high-voltage systems, radio link systems or MRI systems are located within 5 m of the unit, please observe the specifications stated in the installation requirements.

Portable and mobile RF communications equipment may interfere with medical electrical equipment. Therefore, the use of mobile wireless phones in medical offices or hospital environments must be prohibited.

For more details, refer to the document **Electromagnetic Compatibility Information**.

Please also observe the **ESD (ESD: Electro-Static Discharge)** protective measures described below.

Static Discharge

- Connector pins or sockets bearing ESD warning labels must not be touched or interconnected without observing ESD protective measures.

2. Warnings and Precautions



Electrostatic discharge (ESD)

English

ESD protective measures include

- Procedures for preventing electrostatic charge build-up (e.g. air conditioning, air moistening, conductive floor coverings and non-synthetic clothing)
- Discharge the electrostatic charges of your own body on the frame of the UNIT, the protective ground wire or large metallic objects.
- Use the wrist band for grounding.

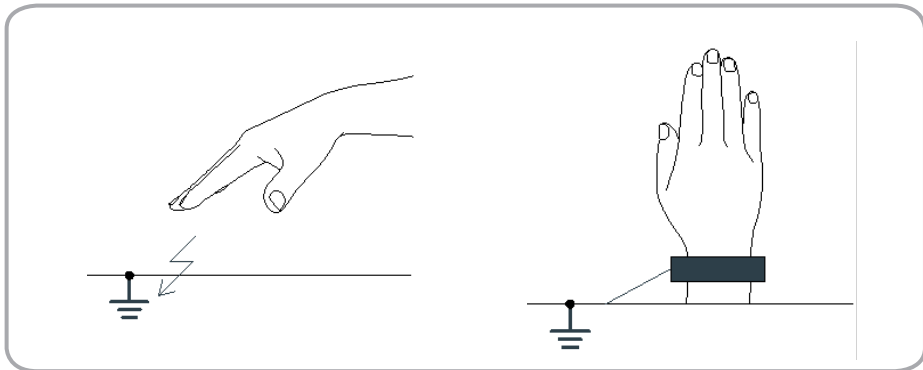

2.3 Radiation Safety



Since rules and regulations concerning radiation safety differ between countries, it is the responsibility of the owner and/or operator of this equipment to comply with all applicable rules and regulations concerning radiation safety and protection in their area.

- The operator must remain outside a shielded room during X-ray exposure in order to protect himself/herself from radiation.
- The patient must wear a lead apron with neck and thyroid protection during X-ray exposure.
- Children and pregnant women must consult with a doctor before X-ray exposure.

2. Warnings and Precautions

- This equipment must be housed inside an X-ray shielded room.
- During imaging; the operator must maintain visual contact with the patient from outside the shielded area.
- The operator should continuously check the status of the patient and the equipment during imaging.
- The operator must immediately stop imaging if the equipment malfunctions.
- The operator should be at least 2 m (6 feet) away from the equipment during imaging.



As a manufacturer of radiology equipment that conforms to stringent protection standards around the world, we guarantee the maximum degree of protection against radiation hazards for our equipment.

2.4 Warnings

The following warning statements should be obeyed with the utmost care. Failure to follow these warnings may cause severe damage to the equipment or physical injuries to the patient and/or operator.



X-ray equipment is hazardous to patient and the operator if proper exposure safety measures and/or operating instructions are not observed.

It is important to read this user manual carefully and strictly abide by all warnings and cautions stated within it.



- 3D image should not be used for screening examinations. Each exam must be justified by demonstrating that the benefits outweigh the risk.

- Where it is likely that evaluation of soft tissues will be required as part of the patient's radiological assessment, conventional medical CBCT or MR should be used instead of dental cone beam imaging.

2. Warnings and Precautions



- PaX-i3D Smart™ system, like other medical equipment, uses high-frequency electrical signals that can interfere with implantable devices such as pacemakers and implantable cardioverter-defibrillators (ICDs). If the patient has such an implantable device, you should be aware of any interference in its operation and immediately power off the Dental X-ray system.
 - PaX-i3D Smart™ system is designed to withstand the effects of defibrillation. However, when possible, disconnect the Dental X-ray systems during defibrillation since a malfunction of the safety controls could otherwise result in electrical burns for the patient.
-



Federal law restricts this device to sale by or on the order of dentist or with the descriptive designation of any other practitioner licensed by the law of the State in which he practices to use or order the use of the device.

Lasers

- The system incorporates Class 1 laser products. The light localizers used in this product are intended for correct patient positioning and must not be used for any other purpose.
 - For maximum safety, advise the patient not to look directly at the laser beam.
 - While adjusting the patient, ensure that the laser beam is not directed at the patient's eyes.
-



Risk of eye injury!

Do not use this equipment with any other laser sources and do not make any changes to the settings or processes that are described in these operating instructions.

2. Warnings and Precautions

■ Cleaning

- Never expose this equipment to liquids, mists or sprays. Exposing this equipment to liquids may cause an electrical shock or otherwise damage the system.
- Do not use spray cleaners on this equipment, as this could cause a fire.

■ During Operation

- Never use this equipment in an environment that is susceptible to explosion.
- Do not place flammable materials near this equipment.
- Do not operate the PC while the equipment is performing an operation. Failure to comply with this instruction may result in system malfunction.
- Immediately stop imaging if the equipment malfunctions in any way.
- If a problem occurs during imaging, press the red emergency stop button to immediately stop all moving parts and cut off all power to the equipment's electrical components.
- Never touch the patient while also touching the SIP/SOP connectors.
- The medical electrical equipment or medical electrical system should not be used adjacent to or stacked with other equipment and that if adjacent or stacked use is necessary, the medical electrical equipment or medical electrical system should be observed to verify normal operation in the configuration in which it will be used.
- The use of accessories, transducers and cables other than those specified, with the exception of transducers and cables sold by the VATECH of the medical electrical equipment or medical electrical system as replacement parts for internal components, may result in increased EMISSIONS or decreased IMMUNITY of EQUIPMENT or SYSTEM.

■ In case of electrical fire

- Use only fire extinguishers designed for electrical fires to extinguish fires on this equipment.

Liquid extinguishers, such as those which use water, could damage the equipment and/or cause injury.

2. Warnings and Precautions

- Unplug the equipment's power cable before extinguishing any fire.

■ Installation

- In order to avoid improperly balanced equipment, install the device on a flat surface to maintain stability.
- If the equipment is not stable, property damage and/or personal injury may occur.
- Do not push or pull the equipment.
- Equipment should only be installed by an authorized technician, complying with proper installation procedures.

■ Security Capabilities

- It is recommended to install and operate EasyDent/EzDent-i SW within secure operating environment that allows only authorized users to access and the system network is equipped with Window firewall built-in Windows system, windows Defender antispysware tools and other commonly used 3rd party security tools and application systems.
- The latest updates for anti-virus software and a firewall is recommended.
- The software can be updated by the manufacturer only. Unauthorized software update through a third party, not the manufacturer, is strictly prohibited. For cyber security issues related to the software and medical devices, please contact the manufacturer.

3 | Imaging System Overview

- 3.1 Introduction 18
- 3.2 Imaging System Configuration..20
- 3.3 Equipment Overview22

3. Imaging System Overview

3.1 Introduction

PaX-i3D Smart is an advanced digital dental diagnostic system that incorporates Panoramic (PANO), Cephalometric (CEPH), and CBCT imaging capabilities into a single system.

3.1.1 Intended Use

PaX-i3D Smart(PHT-30LFO) is a computed tomography x-ray system intended to produce panoramic, cephalometric or cross-sectional images of the oral anatomy on a real time basis by computer reconstruction of x-ray image data from the same axial plane taken at different angles. It provides diagnostic details of the anatomic structures by acquiring 360° rotational image sequences of oral and maxillofacial area for a precise treatment planning in adult and pediatric dentistry . The device is operated and used by physicians, dentists, and x-ray technicians.

3.1.2 System Components

- PaX-i3D Smart digital x-ray equipment
- PC system
- Imaging Software
- EasyDent / EzDent-i: 2D viewer and patient management software
- Ez3D plus / Ez3D-i: 3D viewer and image analysis software

3.1.3 Features

- Low dose Imaging
- 3D Pan and Real 2D image acquisition by single scan
- 3D Viewer: 3D imaging supports precision analysis and diagnosis
- Supports the international digital imaging standard DICOM

3. Imaging System Overview

3.1.4 PaX-i3D Smart Options

| Model | Item | Sensor | |
|-------|-----------------|-----------|-------------|
| SP | PANO+CBCT | PANO/CBCT | Xmaru1404CF |
| SC | PANO+CBCT +CEPH | PANO/CBCT | Xmaru1404CF |
| | | CEPH | Xmaru2301CF |
| OP | PANO+CBCT +CEPH | PANO/CBCT | Xmaru1404CF |
| | | CEPH | 1210SGA |

3.1.5 Standards and Regulations

Standards

PaX-i3D Smart was designed and developed to comply with the following international standards and regulations.

IEC/EN 60601-1(3rd), UL 60601-1(1st), IEC/EN 60601-1-3, IEC 60601-2-63

21 CFR 1020.30, 31, 33

NEMA Standard publication PS 3.1-3.18, 2008



This is Class 11b equipment and received the CE mark for regulations compliance in accordance with the revised Medical Devices Directive 93/42 EEC.



This equipment received the CSA certification mark in accordance with CAN/CSA C22.2 No.601.1 regulations.

Classification (IEC60601-1 6.1)

- Degree of protection against the ingress of water: Ordinary Equipment: IPX0
- Degree of protection against electric shock: Class 1 equipment, Type B Applied Parts



3. Imaging System Overview

3.2 Imaging System Configuration

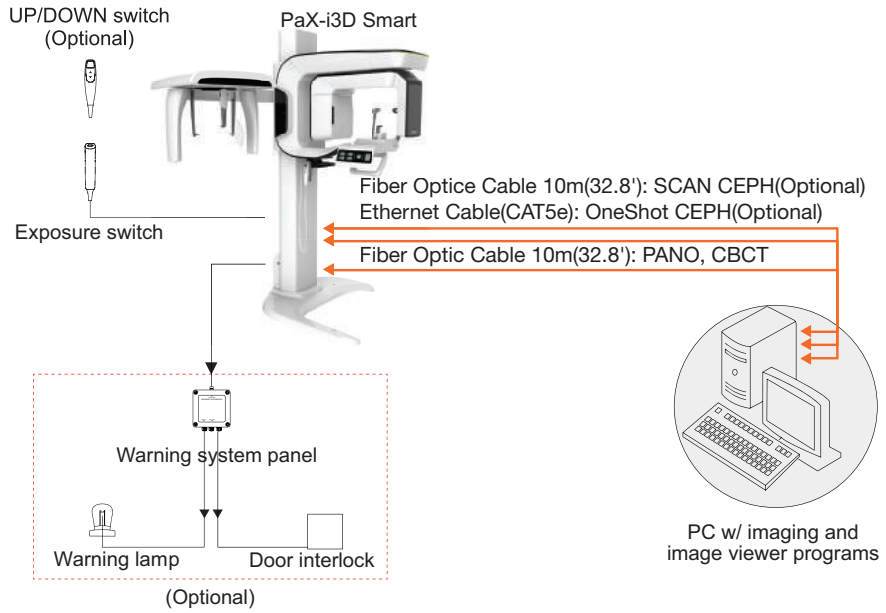

3. Imaging System Overview

PC Signal Input / Output

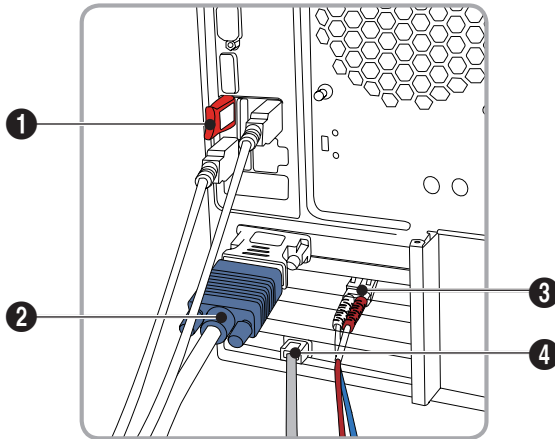

| No. | Parts |
|-----|--|
| 1 | 3D Viewer License Key |
| 2 | Video out |
| 3 | Fiber optic cable in / out x 2 (PANO/CBCT, CEPH) |
| 4 | Ethernet cable(CAT5e) for OneShot CEPH(optional) |

3. Imaging System Overview

3.3 Equipment Overview

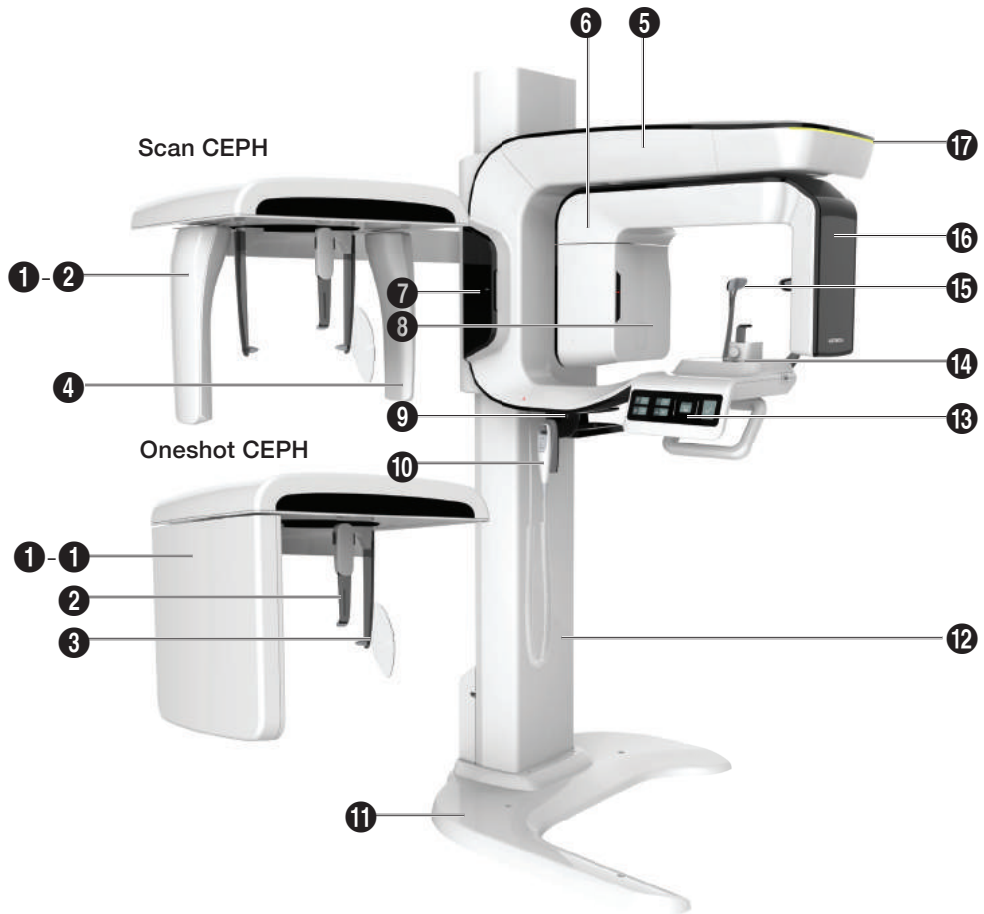

3. Imaging System Overview

| No. | Name | Function |
|-----|--|---|
| 1 | X-ray Sensor (CEPH) | CEPH imaging sensor (optional) 1-1. One shot Type 1-2. Scan Type |
| 2 | Nasal Positioner | Positions the patient during CEPH imaging. The ruler for use to compensate the acquired image that is different from actual size. |
| 3 | Ear Rod | Secure the patient's head during CEPH imaging. |
| 4 | Secondary Collimator | Limits the X-ray irradiation field for CEPH scanning. |
| 5 | Vertical Frame | Holds the Rotating Unit. Use the Vertical Frame Up/Down switch. |
| 6 | Rotating Unit | Rotates around the patient's head as image is being acquired. Movement depends on the scan mode. |
| 7 | Enclosed Component Storage | Place where bite blocks, integrated chin rests and the other components are stored. |
| 8 | X-ray Tube | The vacuum tube where the x-ray is produced. |
| 9 | Emergency Switch | Powers off the equipment when there is a problem during operation. |
| 10 | Vertical Frame Up/Down Switch (optional) | Adjusts the height of the vertical frame. |
| 11 | Base (optional) | Balances the equipment and maintains its safety. |
| 12 | Stationary Column | A fixed column. |
| 13 | Control Panel | Operates the horizontal beam, opens/closes temple supports, and adjusts the height of the vertical frame and prepares for operation when the Ready button is pressed. |

3. Imaging System Overview

| No. | Name | Function |
|-----|-----------------------------|--|
| 14 | Chin Rest | A place to rest the chin. |
| 15 | Temple Supports | Patient head support: Use in PANO and CBCT modes. |
| 16 | X-ray Sensor (PANO/CBCT) | PANO / CBCT Sensor |
| 17 | LED Lamp | Indicates the emission status while the x-ray is in operation. - Green: Ready - Yellow: X-ray ON |

3. Imaging System Overview

3.3.1 Control Panel

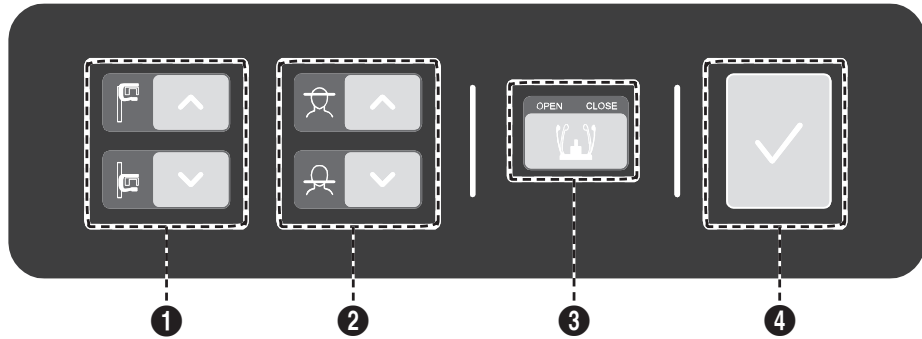

| No. | Button | Description |
|-----|----------------------------------|---|
| 1 | Vertical Frame Up/Down button | Adjusts the vertical frame by moving vertically. |
| 2 | Horizontal Beam Control button | Positions the horizontal beam in PANO mode. |
| 3 | Temple Support OPEN/CLOSE button | Adjusts the temple supports to position the patient. |
| 4 | READY/ RETURN button | When pressed, prepares for operation after positioning the patient and configuring the environment settings. Initializes the positioning of the rotating unit. |

3. Imaging System Overview

3.3.2 Emergency Stop Switch

During operation, the following emergency situations may occur:

- X-ray emission continues after the exposure switch has been released
- Injury to the patient or damage to the equipment
- Other emergency situations

If a problem occurs during image acquisition, press the red **Emergency Stop Switch** to immediately stop the moving parts and cut off all power to the equipment's electrical components. To reset the **Emergency Stop Switch**, turn it clockwise until it pops up.

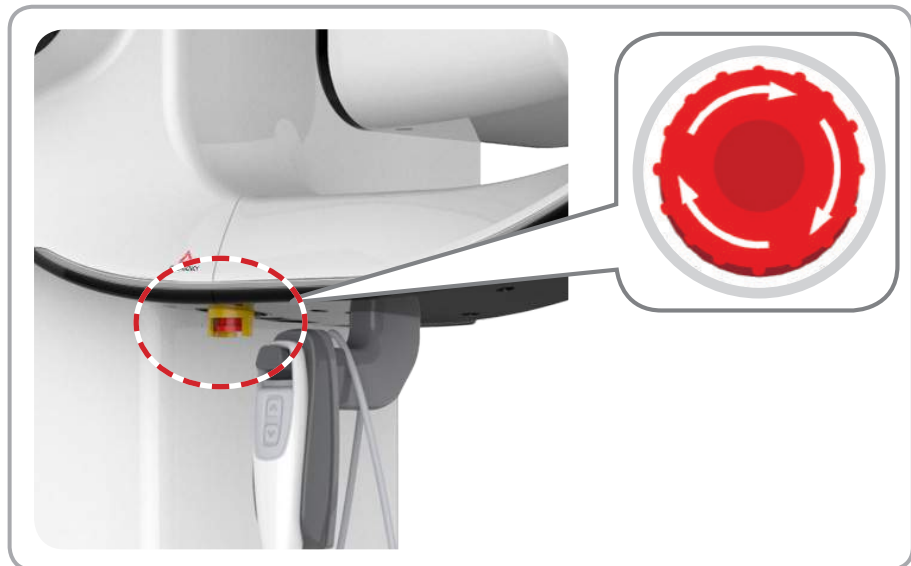

3. Imaging System Overview

3.3.3 Exposure Switch

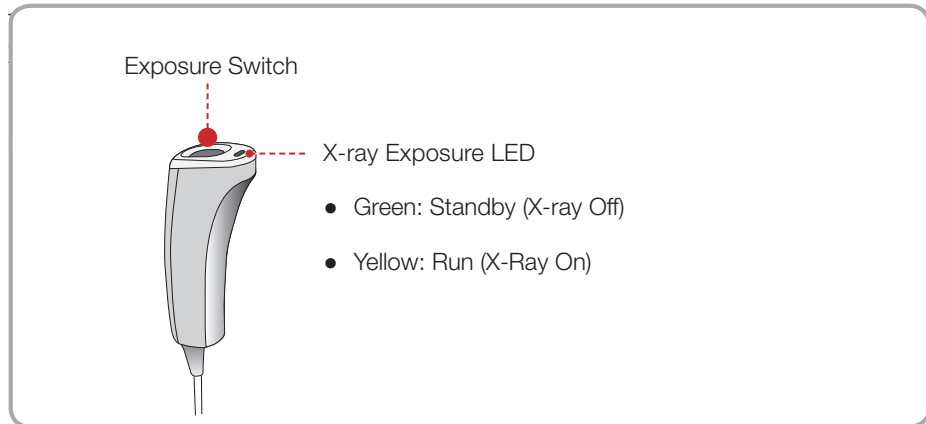

The exposure switch is detachable. Ensure the exposure switch cable is not pulled out from the unit accidentally during operation.

3. Imaging System Overview

3.3.4 Enclosed Component

The enclosed components can be disassembled and cleaned. All enclosed components that are used to support the patient (bite block, chin rest and temple supports) should be cleaned with ethanol and wiped with clean towels.

| Components | Name and Function |
|---|---|
|  | Bite Block |
|  | Temple Supports (1 set) |
|  | TMJ Bite |
|  | Sinus/Edentulous Bite |
|  | Sinus Chin Rest |
|  | Ear Rod (1 set) |
|  | Nasal Positioner Cover (for CEPH) |
|  | Carpus Plate |
|  |  Integrated Chin Rest Sanitary Vinyl Covers (disposable): Bite Block |
|  | Protractor (1 set): Use to position the body in CEPH mode. |

4 | Imaging Software Overview

| | | |
|------------|----------------------------------|-----------|
| 4.1 | PC Specifications..... | 30 |
| 4.2 | EasyDent / EzDent-i | 32 |
| 4.3 | Console Software..... | 33 |

4. Imaging Software Overview

Three programs come with this equipment to acquire, process, and view the image:

- **EasyDent / EzDent-i:** 2D viewer, analysis, and patient management
- **Ez3D plus / Ez3D-i:** 3D Viewer and analysis
- **Console software:** PANO / CEPH / CBCT

4.1 PC Specifications



- The PC system plays an important role in image processing and verification. Configure the PC environment to meet the following specifications. If the PC specifications are not met, the image quality may be low.
- Do not place patients near the equipment and PC.

| Item | Recommended Specification |
|---------------------|---|
| CPU | E5-1607v4 4C 3.1GHz 2133 10MB |
| RAM | 2x8GB DDR4-2400 Registered RAM |
| Hard disk drive | 1TB SATA 7200 rpm |
| Graphics board | NVIDIA GeForce GTX1060 6GB |
| Ethernet interface | Integrated Intel I218LM PCIe GbE Controller Intel Ethernet I210-T1 PCIe NIC (Option) |
| Serial Port (RS232) | HP Serial Port Adapter Kit (Option) |
| Power supply | ≥ 700 Watts (90 % Efficiency) |
| Slots | 2 PCI Express Gen3 x 16 slots 1 PCI Express Gen3 x 8 slot 1 PCI Express Gen2 x 4 slot 1 PCI Express Gen2 x 1 Slot 1 PCI 32bit/33MHz |
| CD/DVD drive | DVD Writer 5.25" |
| Monitor | 19" 1280 x 1024 screen resolution |

4. Imaging Software Overview

| Item | Recommended Specification |
|--------------------|---|
| Operating system | Windows 7 Professional 64-bit (available through downgrade rights from Windows 10 Pro) |
| Recommended system | HP Z440 |

4. Imaging Software Overview

4.2 EasyDent / EzDent-i

EasyDent / EzDent-i is dental imaging software from Vatech Co. Ltd that manages patient images so you can make faster, more accurate diagnoses. The console software and 3D Viewer are linked with **EasyDent / EzDent-i** making it convenient for the user to use and process necessary images. Various functions can be used so that acquired images can be processed quickly and conveniently from the console software.



Please refer to **5.3 Creating New Patient** and **5.4 Retrieving Patient Information** and EasyDent / EzDent-i User manual for more information.



Security Capabilities

- It is recommended to install and operate EasyDent/EzDent-i SW within secure operating environment that allows only authorized users to access and the system network is equipped with Window firewall built-in Windows system, windows Defender antispyware tools and other commonly used 3rd party security tools and application systems.
 - The latest updates for anti-virus software and a firewall is recommended.
 - The software can be updated by the manufacturer only. Unauthorized software update through a third party, not the manufacturer, is strictly prohibited. For cyber security issues related to the software and medical devices, please contact the manufacturer.
-

4. Imaging Software Overview

4.3 Console Software

Use the console software to configure the imaging environment according to the mode.



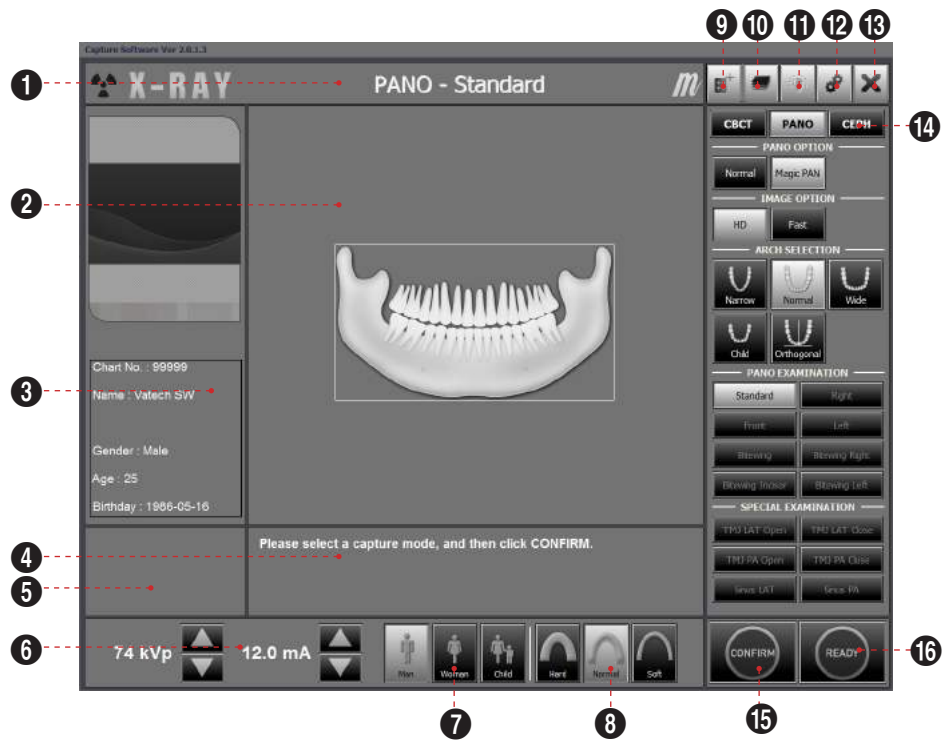

- To improve program functions, the console software may change without notice.

The main screen of the Console Software consists of the following. Each one of the different modes will be described later.









4. Imaging Software Overview

| No. | Function | Description |
|-----|--|--|
| 1 | Imaging Mode Display | <p>This displays the current imaging mode.</p> <hr/> <div style="display: flex; align-items: center;">  <ul style="list-style-type: none"> • Indicates that the Magic PAN is supported in the PANO imaging modality. • Is displayed only for the Standard mode, with the Magic PAN enabled. </div> <hr/> |
| 2 | Scanning Status and Image Preview Window | This shows image acquisition progression in real-time. |
| 3 | Patient Information | This displays information about the selected patient. |
| 4 | Imaging Guide Window | This displays various text instructions for the operator to follow. |
| 5 | Scan Time and DAP Display Window | Upon clicking CONFIRM , the scan time and estimated DAP value is displayed in this window. |
| 6 | Tube Voltage and Current Adjustment | <p>If the patient is selected in EasyDent / EzDent-i, the default kVp/mA according to the patient's information (gender/age) is displayed. This tool adjusts the kVp and mA values or control the power of the X-ray in order to improve image quality. If necessary, adjust the kVp and mA values manually using the arrows.</p> <hr/> <div style="display: flex; align-items: center;">  <div style="padding-left: 10px;"> <p>For the tube voltage and its correspondence with the current patient, refer to Appendix > 13.1 Recommended X-ray Exposure Table.</p> </div> </div> <hr/> |



4. Imaging Software Overview

| No. | Function | Description | | | | | | | | | | | | | | | | | | | | |
|--------------------|----------------------------|---|--------------------------------------|----------------------------|-------------------|--------------------------------------|-------|---------------------|--------|------|-------------------|--------|--------|------|-------|---------|--------|------|------|--------|--------|------|
| 7 | Patient Gender | <p>This displays the current patient's gender as entered in EasyDent / EzDent-i's patient information. If necessary, gender can be manually selected.</p> <table border="1"> <thead> <tr> <th colspan="2">Age Group / Gender</th> <th>VATECH's Standard</th> </tr> </thead> <tbody> <tr> <td colspan="2">Child</td> <td>2 ~ 12 years of age</td> </tr> <tr> <td rowspan="2">Adult</td> <td>Man</td> <td rowspan="2">> 12 years of age</td> </tr> <tr> <td>Woman</td> </tr> </tbody> </table> | Age Group / Gender | | VATECH's Standard | Child | | 2 ~ 12 years of age | Adult | Man | > 12 years of age | Woman | | | | | | | | | | |
| Age Group / Gender | | VATECH's Standard | | | | | | | | | | | | | | | | | | | | |
| Child | | 2 ~ 12 years of age | | | | | | | | | | | | | | | | | | | | |
| Adult | Man | > 12 years of age | | | | | | | | | | | | | | | | | | | | |
| | Woman | | | | | | | | | | | | | | | | | | | | | |
| 8 | X-ray intensity | <p>This tool selects X-ray intensity.</p> <hr/> <p>Depending on the circumference of the patient's head, X-ray intensity may be classified as Hard, Normal, or Soft :</p> <p>Soft ≤ Normal ≤ Hard</p> <table border="1"> <thead> <tr> <th>Age Group</th> <th>Average head circumference</th> <th>Range (cm)</th> <th>Classification of head circumference</th> </tr> </thead> <tbody> <tr> <td rowspan="3">Child</td> <td rowspan="3">53±3 cm</td> <td>> 53±3</td> <td>Hard</td> </tr> <tr> <td>53±3</td> <td>Normal</td> </tr> <tr> <td>53±3 <</td> <td>Soft</td> </tr> <tr> <td rowspan="3">Adult</td> <td rowspan="3">56±3 cm</td> <td>> 56±3</td> <td>Hard</td> </tr> <tr> <td>56±3</td> <td>Normal</td> </tr> <tr> <td>56±3 <</td> <td>Soft</td> </tr> </tbody> </table> | Age Group | Average head circumference | Range (cm) | Classification of head circumference | Child | 53±3 cm | > 53±3 | Hard | 53±3 | Normal | 53±3 < | Soft | Adult | 56±3 cm | > 56±3 | Hard | 56±3 | Normal | 56±3 < | Soft |
| Age Group | Average head circumference | Range (cm) | Classification of head circumference | | | | | | | | | | | | | | | | | | | |
| Child | 53±3 cm | > 53±3 | Hard | | | | | | | | | | | | | | | | | | | |
| | | 53±3 | Normal | | | | | | | | | | | | | | | | | | | |
| | | 53±3 < | Soft | | | | | | | | | | | | | | | | | | | |
| Adult | 56±3 cm | > 56±3 | Hard | | | | | | | | | | | | | | | | | | | |
| | | 56±3 | Normal | | | | | | | | | | | | | | | | | | | |
| | | 56±3 < | Soft | | | | | | | | | | | | | | | | | | | |

4. Imaging Software Overview

| No. | Function | Description |
|-----|--|---|
| 9 | Phantom Capture  | <p>This function is used when the Phantom Jig is being used to acquire images.</p> <hr/> <p>Image acquisition using the Phantom Jig:</p> <ol style="list-style-type: none"> 1. Click Phantom Capture Icon. 2. Select the Modality, followed by OK. 3. Check the parameters displayed in the main GUI window. If correct, click the 'Confirm' button.  4. Align the Phantom Jig, and click the 'Ready' button. 5. Press and hold down the exposure switch. |
| 10 | Manual Image Reconstruction  | If automatic reconstruction of the image fails, use this function to reconstruct the image manually. Select Modality and click Search Reconstruction. |
| 11 | Laser Beam On / Off Button  | Use this icon to turn the laser beam on or off for patient positioning. This button is enabled when the CONFIRM button is clicked after the imaging environmental parameters are configured. |
| 12 | Settings  | This Control Panel displays and sets various equipment-related parameters, including language, automatic save, DAP display unit, etc. |
| 13 | Exit  | This button exits the capturing program. |
| 14 | Imaging Mode | This selects an imaging mode – PANO, CEPH or CBCT. |

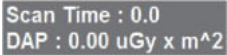
4. Imaging Software Overview

| No. | Function | Description |
|-----|----------|--|
| 15 | CONFIRM | <p>After confirming all settings required for scanning, press CONFIRM to apply the settings.</p> <hr/>  <p> When you click CONFIRM, the scan time and estimated DAP (Dose Area Product) value will be shown on the main display for the exposure you are going to take.</p> <hr/> |
| 16 | READY | <p>This button is used when all aspects of preparation have done for image acquisition (including parameter settings and patient positioning)</p> |

5 | Getting Started

- 5.1 Turning On Equipment40
- 5.2 Running the Image Viewer42
- 5.3 Initiating the Console Software .
.....48

5. Getting Started

5.1 Turning On Equipment



- Do not place the patient close to the equipment is on. Doing so may cause injury to the body and damage to equipment.
 - Do not turn on the PC while the equipment is in operation. Doing so may cause an error.
-



- Excessive temperature changes may cause condensation to form on the equipment. When room temperature is reached, turn on the equipment.
 - Equipment rebooting: After turning it off, the equipment may be turned on again after 20 seconds.
 - Warm-up the equipment for at least 5 minutes before the operation. For the best image quality, it is recommended that equipment be warmed-up for 30 minutes or more.
-



If the equipment has not been used for a long time, please leave enough time to warm-up the equipment. It extends the life of the x-ray tube.

The imaging system mainly consists of the imaging equipment and the PC.

Before turning on the equipment, please confirm the equipment and PC correctly installed.

5. Getting Started

1. Turn on the PC.
2. Press the switch that is located under the handle frame to turn on the equipment.

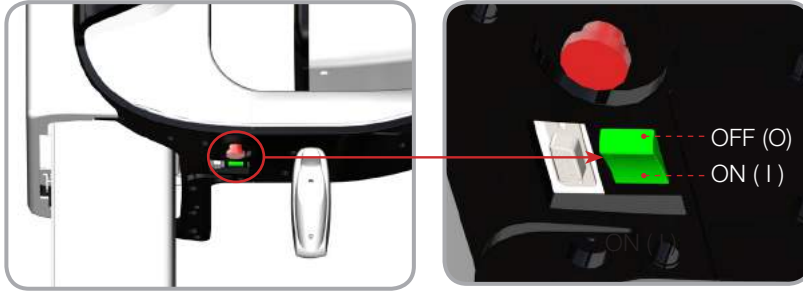

3. Confirm the green LED light at the top of the equipment is on.
4. (Optional) Plug the license key for the 3D Viewer(Ez3D plus) into the PC.

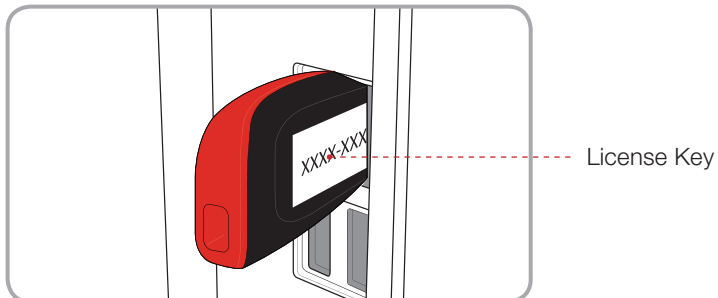

5. Getting Started

5.2 Running the Image Viewer

EasyDent / EzDent-i is a basic imaging platform for all VATECH's dental X-ray equipments. The Imaging Program is interfaced with **EasyDent / EzDent-i**. On your desktop, double-click **EasyDent / EzDent-i** icon. The **EasyDent / EzDent-i** main window will be displayed.



For further details on this subject, refer to the EasyDent / EzDent-i user manual.



Security Capabilities

- It is recommended to install and operate EasyDent/EzDent-i SW within secure operating environment that allows only authorized users to access and the system network is equipped with Window firewall built-in Windows system, windows Defender antispyware tools and other commonly used 3rd party security tools and application systems.
 - The latest updates for anti-virus software and a firewall is recommended.
 - The software can be updated by the manufacturer only. Unauthorized software update through a third party, not the manufacturer, is strictly prohibited. For cyber security issues related to the software and medical devices, please contact the manufacturer.
-



For PHT-30LFO dental computed tomography X-ray system, both 3D Viewer(Ez3D plus/Ez3D-i) and console software are being accessed through 2D Viewer(EasyDent/EzDent-i) SW. 3D Viewer and console software do not have image storage capability of its own and both programs will not be able to patient information.

5. Getting Started

5.2.1 Creating a New Patient Record

To create a new patient record, follow the procedure outline below:

EasyDent

A. Click the **Patient** icon on the upper left corner of the EasyDent's main GUI window.

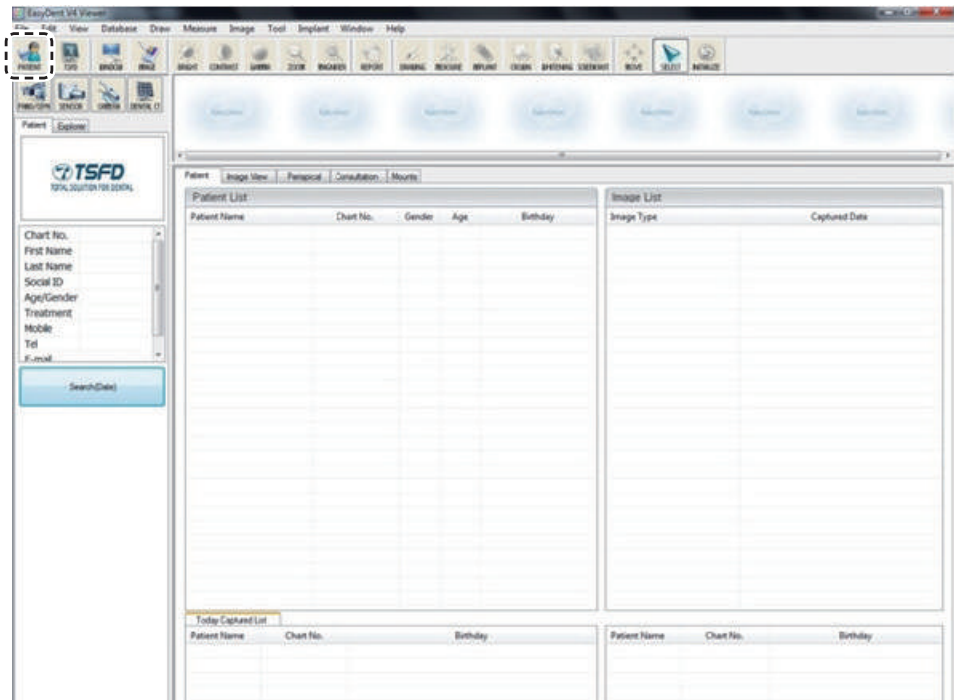

5. Getting Started

B. The following dialog box will open.

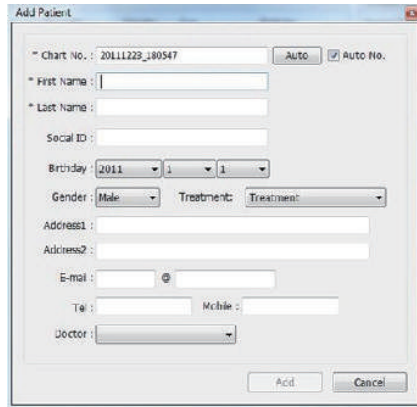

C. Enter the required patient information. **Chart Number, First Name, and Last Name** are required fields which must be filled in. All other fields are optional, but it is recommended that they be filled in.

D. Click **Add** to save the patient record.

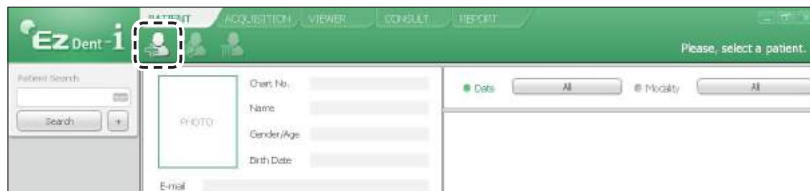

B. Enter the required patient information. The **Chart Number, E-Mail address, First Name, and Last Name** are required fields which must be filled in. (The chart number fills

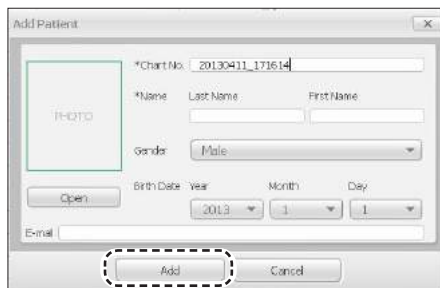

5. Getting Started

C. Click **Add** to save the patient record.

Limit Access to Trusted Users Only



- EzDent software requires each operator to set up a unique user ID and password to prevent any unauthorized access to patients' confidential information.
- User ID and password can be assigned to give permission to register, add, delete and modify patient information and diagnostic images. The application of User ID and password authentication assures the accountability that the prescribed access process is being done by an authorized user.
- According each operator's privilege level, the login enables the user to search, register, modify and delete the patient information or diagnostic images. Different search criteria suggest availability of the patient information being sought.
 - Search by ID: Search by ID is possible if the patient id is known.
 - Search by Name: Search by the name of the patient is possible.
 - Search by age and gender can be used to divide the search result further, for patients with the same name.
- The user's Login/Logout time and work duration can be traced via log data.

5. Getting Started

5.2.2 Retrieving Patient Records

EasyDent

You can search through the patient database using a patient's chart number, their first name, or their last name.

A. On the **Patient information pane**, double-click the **Chart No., First name, or Last name** of the patient and the virtual keyboard will pop up.



B. Enter **the Chart No., First name, or Last name** of the patient by clicking the mouse on the virtual key board and click the **Enter** (The physical keyboard can be used to do the same job).

C. Patient information can be displayed on the **Patient information pane** and **Patient List**.

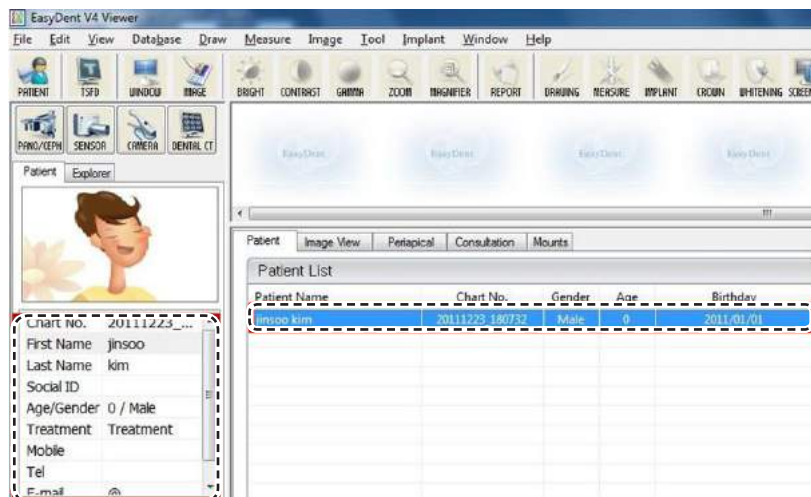

5. Getting Started

EzDent-i

A. Enter the name or chart number of the patient to be searched on the **Search** pane and then click the **Search** button. The information on the patient that fits the search condition appears.

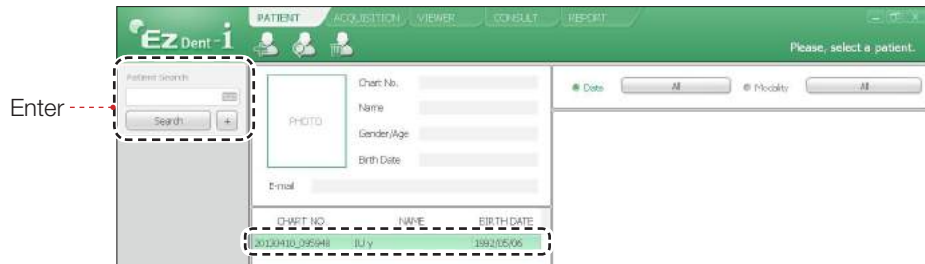

Double-click the Keyboard icon to display the virtual keyboard. You may search patient information using the virtual keyboard.



B. Double-click the patient information to see more details about the patient as shown

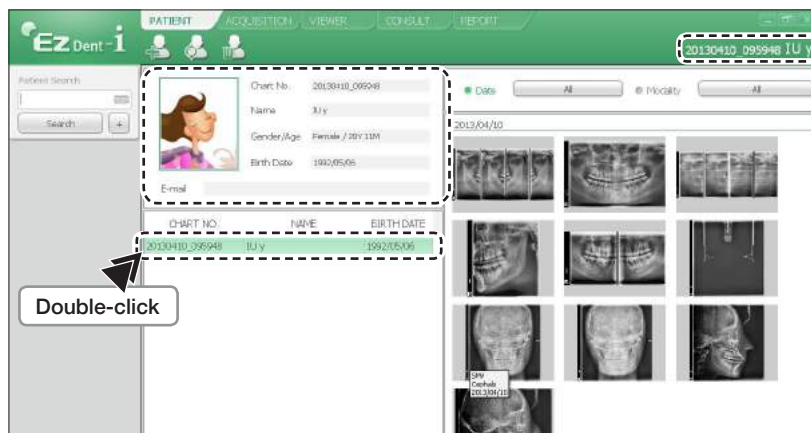

5. Getting Started

5.3 Initiating the Console Software



For a new patient, first register the patient information.

EasyDent

A. First, click the patient information in the patient list, and click the **Dental CT** icon () in the upper left corner of the EasyDent's main window to open the imaging program.



B. The following imaging program window opens. The sole purpose of this window is to control equipment settings and acquire images.

5. Getting Started



5. Getting Started

EzDent-i



B. Click **Acquisition** and the imaging mode (CT, Panorama, or Cephalo).



C. The main screen for the selected mode appears. (See **4.3 Imaging Software Overview**). From the main screen, you can configure the imaging parameter settings prior to acquiring an image.

Please proceed to the next chapter.



Refer to chapters 6 - 8 for information regarding image acquisition.















6 | Acquiring PANO

- 6.1 Setting Exposure Parameters ..
.....57
- 6.2 Patient Positioning61
- 6.3 X-ray Exposure.....76
- 6.4 Finishing Scan.....77
- 6.5 Confirming Image.....77

6. Acquiring PANO images

To acquire PANO Images, first **5. Getting Started** must be completed. If **5. Getting Started** is not completed, you must go back to the **5. Getting Started** and finish the step first.







PANO Examination Program

| Examination | Arch Selection | Examination Program | |
|---------------------|--|---|-------------------|
| PANO EXAMINATION | Narrow, Normal, Wide, Child , Orthogonal |  | Standard |
| | |  | Right |
| | |  | Front |
| | |  | Left |
| | |  | Bitewing* |
| | |  | Bitewing Incisor* |
| | |  | Bitewing Right* |
| | |  | Bitewing Left* |
| SPECIAL EXAMINATION | - |  | TMJ LAT Open |
| | |  | TMJ LAT Close |
| | |  | TMJ PA Open |
| | |  | TMJ PA Close |
| | |  | Sinus LAT |
| | |  | Sinus PA |

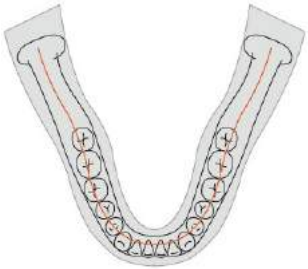

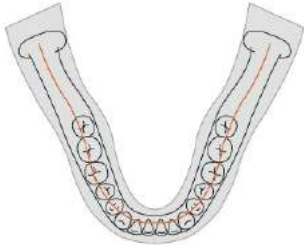
* Bitewing examinations are available only when Orthogonal Arch is selected.

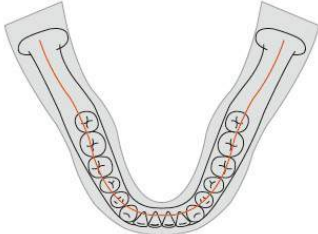
6. Acquiring PANO images

Arch Selection



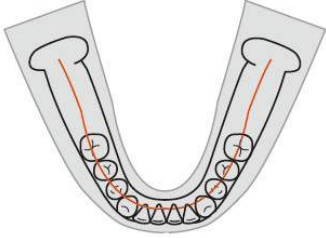

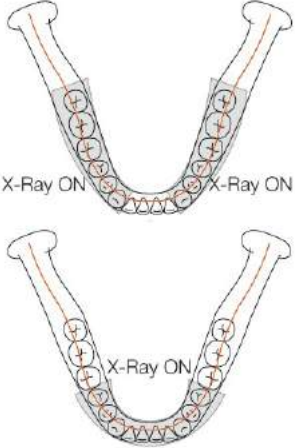
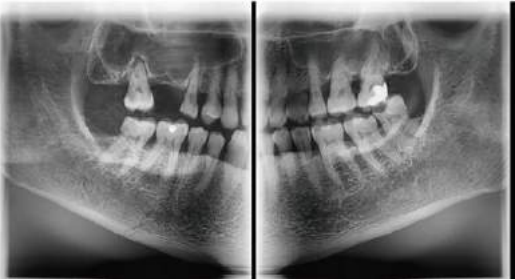
| Examination Program | Image |
|---|--|
| <p data-bbox="275 436 1153 498">Narrow (Standard): Panoramic image of V-shaped palatal arches (small number of adult females)</p>  <p>The diagram shows a narrow, V-shaped palatal arch. The teeth are represented by small circles with a cross inside, arranged in a tight, narrow curve. The arch is highlighted in red.</p> |  <p>A panoramic radiograph showing a narrow, V-shaped palatal arch. The teeth are closely spaced, and the arch is clearly visible as a narrow curve.</p> |
| <p data-bbox="275 826 998 857">Normal (Standard): Panoramic image of normal adult palatal arches</p>  <p>The diagram shows a normal, U-shaped palatal arch. The teeth are represented by small circles with a cross inside, arranged in a standard U-curve. The arch is highlighted in red.</p> |  <p>A panoramic radiograph showing a normal, U-shaped palatal arch. The teeth are spaced normally, and the arch is clearly visible as a standard U-curve.</p> |
| <p data-bbox="275 1188 1163 1250">Wide (Standard): Panoramic image of square-shaped palatal arches (some number of adult males)</p>  <p>The diagram shows a wide, square-shaped palatal arch. The teeth are represented by small circles with a cross inside, arranged in a wide, square curve. The arch is highlighted in red.</p> |  <p>A panoramic radiograph showing a wide, square-shaped palatal arch. The teeth are widely spaced, and the arch is clearly visible as a wide, square curve.</p> |

6. Acquiring PANO images



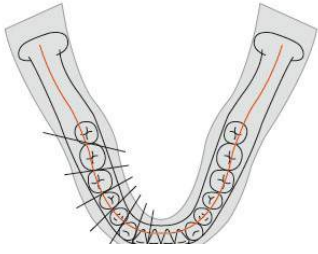

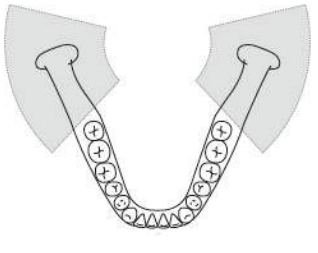
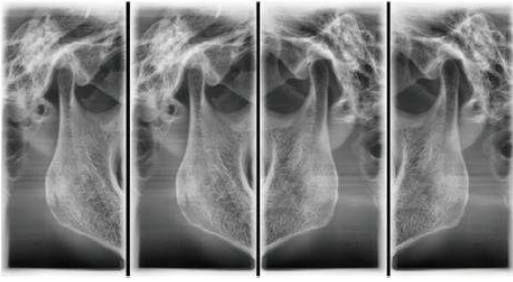
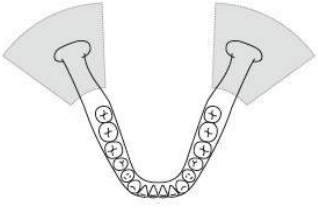
| Examination Program | Image |
|---|---|
| <p data-bbox="278 378 900 407">Child (Standard): Panoramic image of child palatal arches.</p>  |  |
| <p data-bbox="278 739 1119 794">Bitewing: Imaging from targeted areas of palatal arches; less x-ray dose than in Standard mode.</p>  |  |

6. Acquiring PANO images

SPECIAL EXAMINATION

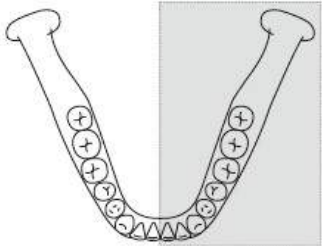
| Examination Program | Image |
|--|--|
| <p>Orthogonal (Standard): Panoramic image where the x-ray angle enters vertically in between the teeth so overlapping images are minimized.</p> | |
|  |  |
| <p>TMJ LAT Open / Close: The acquired image focused on the lateral TMJ area.</p> | |
|  |  |
| <p>TMJ PA Open / Close: The acquired image focused on the posterior-anterior TMJ area.</p> | |
|  |  |

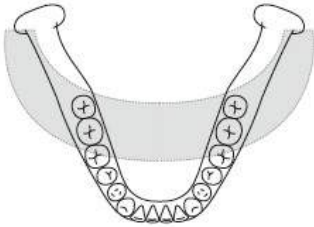
6. Acquiring PANO images

| Examination Program | Image |
|---|---|
| Sinus LAT: The acquired image focused on the lateral Maxillary Sinus area. | |
|  |  |
| Sinus PA: The acquired image focused on the posterior-anterior Maxillary Sinus area. | |
|  |  |

6. Acquiring PANO images

6.1 Setting Exposure Parameters

Perform the following procedures to select the capture parameters for the specific patient and capture mode. Please refer to [4.3 Console Software](#) for more information.

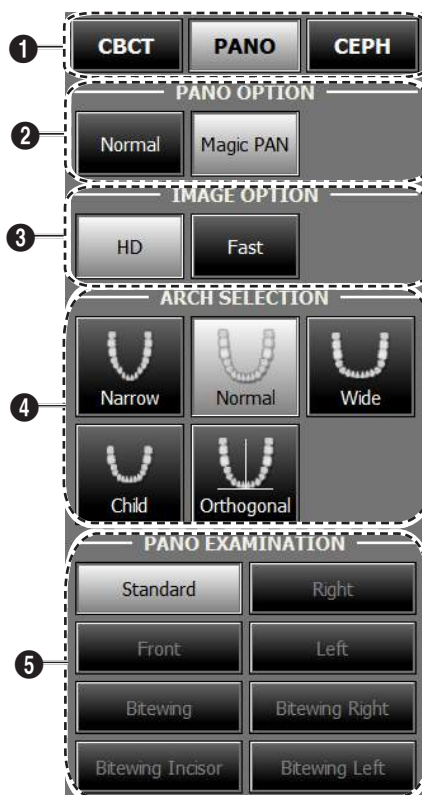

1. Click the PANO button.
2. Select a PANO option.







| Mode | Description |
|-------------------------|--|
| Normal | This is the normal type. |
| Magic PAN (Optional) | Reconstruct an image with optimized focus (autofocus) from the entire panorama to acquire high quality images so any errors caused by issues with the patient's position and tooth trajectory will be minimized. |

6. Acquiring PANO images

3. Select an Image option.

| Mode | Description |
|------|----------------------------------|
| HD | High Definition, High Resolution |
| Fast | Normal Image |

4. Select Arch Selection.

| Arch Selection | Description |
|--|--|
|  Narrow | Panoramic image of V-shaped palatal arches (small number of adult females) |
|  Normal | Panoramic image of normal adult palatal arches |
|  Wide | Panoramic image of square-shaped palatal arches (some number of adult males) |
|  Child | Panoramic image of child palatal arches, 40% less x-ray dose than in Normal mode. |
|  Orthogonal | <p>Panoramic image where the x-ray angle enters vertically in between the teeth so overlapping images are minimized.</p> <hr/> <p> If Orthogonal Arch is selected, four bitewing examinations (bitewing, bitewing incisor, bitewing right, bitewing left) are activated</p> |

5. Select an Examination Program.

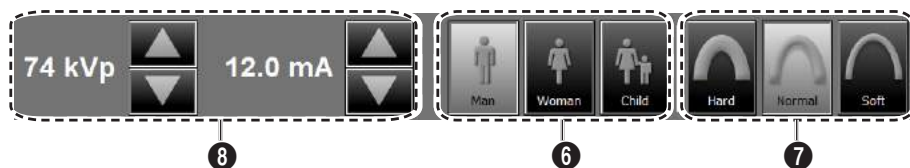

6. The gender of the patient is selected automatically. When necessary, it can be selected manually.

6. Acquiring PANO images

7. Select x-ray intensity.

Depending on the circumference of the patient's head, X-ray intensity may be classified as Hard, Normal, or Soft :

Soft \leq Normal \leq Hard



| Age Group | Average head circumference | Range (cm) | Classification of head circumference |
|-----------|----------------------------|--------------|--------------------------------------|
| Child | 53 \pm 3 cm | > 53 \pm 3 | Hard |
| | | 53 \pm 3 | Normal |
| | | 53 \pm 3 < | Soft |
| Adult | 56 \pm 3 cm | > 56 \pm 3 | Hard |
| | | 56 \pm 3 | Normal |
| | | 56 \pm 3 < | Soft |

- The values of tube voltage and current are configured automatically according to the patient's gender and x-ray intensity. Click the arrow button to zoom in. The dose is adjustable by ± 1 kVp and ± 1 mA respectively.
- Once the configuration has been completed, click the **CONFIRM** button.



When you click **CONFIRM** button:

- The **READY** button will begin blinking to show that it has been activated.



- The Rotating unit will move to its initial scanning position.
- Three laser beams will be activated to make patient positioning easier.

6. Acquiring PANO images

- The **Scan Time** and **DAP** values will be shown on the Imaging Status Window.

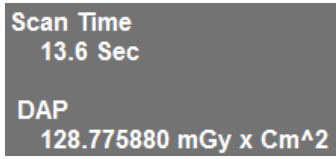

Scan Time
13.6 Sec

DAP
128.775880 mGy x Cm²

10. Guide the patient to the equipment.

6. Acquiring PANO images

6.2 Patient Positioning



- Have patients, especially pregnant women and children, wear a lead apron to protect them from residual radiation.
- Be careful not to direct the laser beam into the patient's eyes. Doing so can result in a permanent loss of vision.



- Correct posture reduces the shadow cast by the patient's cervical spine and allows for clear image acquisition.
- Metal implants or bridges may reduce the quality of the images.
- If the laser beam is not correctly positioned, distortion, where the image may be enlarged or reduced, or ghost shadows may occur and lower the image quality so please be careful.



In general, images are acquired when the patient is standing. In special cases, a chair without a backrest (stool) may be used. Do not obstruct the laser beam or the operation of the equipment with the chair.

Getting prepared

1. Ask the patient to remove all the metal objects (glasses, earrings, hair pins, braces, false teeth). Metal objects may induce ghost images and lower the image quality.
2. Ask the patient to wear a lead apron to protect them from residual radiation.
3. Use the **Vertical Frame Up/Down button** or switch option to adjust the equipment to match the height of the patient.



6. Acquiring PANO images

6.2.1 PANO Standard and Bitewing mode

Patient Positioning

1. Insert the bite block into the chin rest then cover with a sanitary vinyl cover.

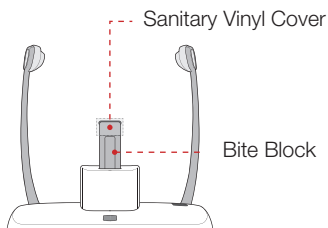

The sanitary vinyl cover is for single use only. It should be replaced after each patient. Be sure to use the approved vinyl cover.



Clean the chin rest and bite block with ethanol and wipe with a dry towel before the next patient.

2. Use the **Temple Support Open/Close** button on the control panel to widen the temple supports.

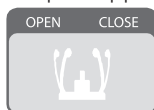

3. Guide the patient to the inside of the equipment.
4. Use the **Vertical Frame Up/Down** button or switch option to adjust the height of the equipment so the patient's chin reaches the chin rest.
5. Guide the patient to stand in the center of the equipment and direct them to remain in the position outlined below.
 - Two hands: Hold the handles of the equipment tightly.
 - Chest: Press against the equipment.
 - Two feet: Keep both feet close to the inside of the base.

6. Acquiring PANO images

- Shoulders: Keep your shoulders relaxed and balanced.
- Cervical Spine: Straighten your body and stand still.

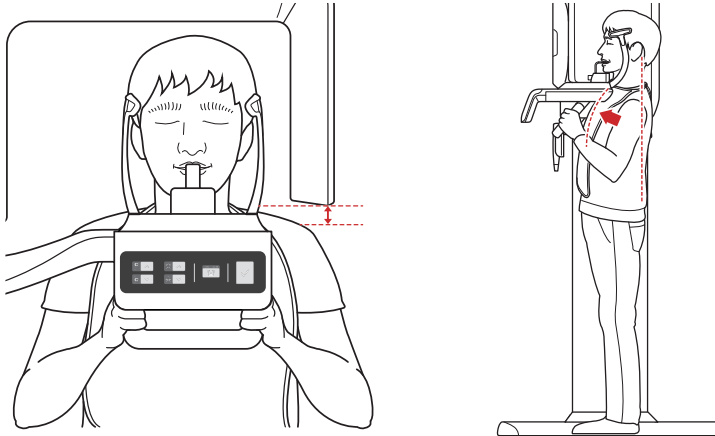

- Make sure that there is no interference between the sensor housing and the shoulder.
- Ask the patient to loosen his/her hair if it is tied back.

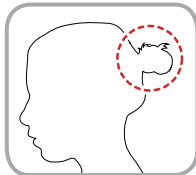

6. Direct the patient to correctly bite into the bite block groove with their front teeth.
7. Direct the patient to maintain the posture as described below.

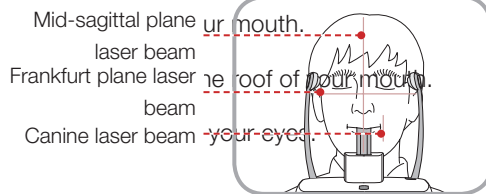

6. Acquiring PANO images

Edentulous Patient Positioning

1. Remove the bite block from the chin rest.

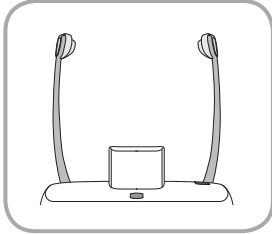

2. Insert the Sinus/Edentulous Bite into the chinrest.

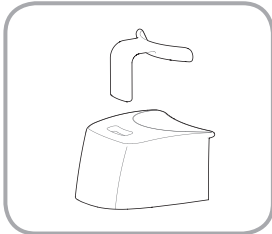

3. Use the **Temple Support Open/Close** button on the control panel to widen the temple supports.
4. Guide the patient to the inside of the equipment.
5. Use the Vertical Frame Up/Down button or switch option to adjust the height of the equipment so the patient's chin reaches the chin rest.
6. Guide the patient to stand in the center of the equipment and direct them to remain in the position outlined below.
 - Two hands: Hold the handles of the equipment tightly.
 - Chest: Press against the equipment.
 - Two feet: Keep both feet close to the inside of the base.
 - Shoulders: Keep your shoulders relaxed and balanced.
 - Cervical Spine: Straighten your body and stand still.

6. Acquiring PANO images

7. Direct the patient to maintain the posture as described below.

- Mouth: Close your mouth.
- Tongue: Touch the roof of your mouth.
- Two eyes: Close your eyes.



Correct posture reduces the shadow cast by the patient's cervical spine and allows for clear image acquisition.

During image acquisition, direct the patient to maintain the posture as described below.

- Two hands: Hold the handles of the equipment tightly.
- Chest: Press against the equipment.
- Two feet: Keep both feet close to the inside of the base.
- Shoulders: Keep your shoulders relaxed and balanced.
- Cervical Spine: Straighten your body and stand still.
- Mouth: Bite the bite block and close your mouth.
- Tongue: Touch the roof of your mouth.
- Two eyes: Close your eyes.

Ask the patient to maintain their position and to not move until the image acquisition is completed.

6. Acquiring PANO images

Laser Beam Positioning



Be careful not to shine the laser beam directly into the person's eyes.

Doing so may result in vision loss.



If the laser beam is not correctly positioned, distortion, where the image may be enlarged or reduced, or ghost shadows may occur and lower the image quality. Be sure to align the laser beam properly.

1. Align the vertical beam with the center of the face. (To prevent horizontal expansion of the image)
2. Align the horizontal beam in a straight line with the Frankfurt line on the patient's face. Use the Horizontal Beam button on the control panel to position it. Check to see that the horizontal beam aligns with the patient's face horizontally.

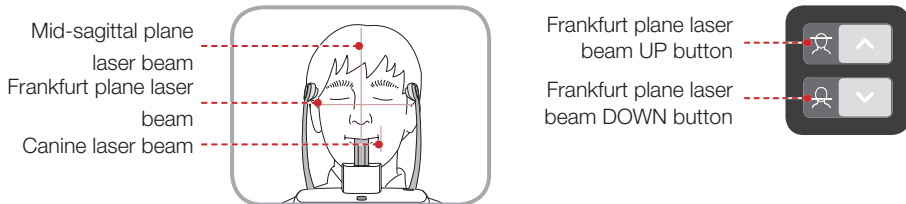

3. Direct the patient to smile and align the canine teeth beam with the center of the canines. Use the Canine Teeth Beam level to adjust the position of the beam.

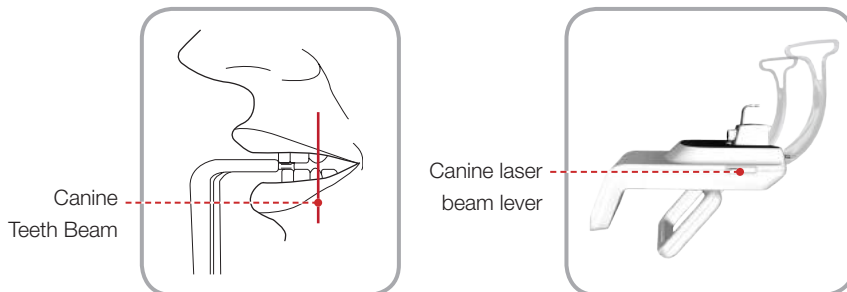

6. Acquiring PANO images

Finishing Patient Positioning

1. After checking the positions of the patient and the laser beam, click the **Temple Support Open/Close** button on the control panel to prevent the patient's head from moving.

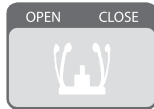

Make sure that the Temple Support is in **Close** position before clicking the **READY** button.

2. Click the **READY** button. The x-ray exposure has not started yet.
3. Now go to **6.3 X-ray Exposure** to begin operation.

6. Acquiring PANO images

6.2.2 TMJ Open Mode

Acquire the TMJ Close image after the TMJ Open image has been acquired.



Steps for TMJ Mode

TMJ Open positioning > Align Laser Beam > X-ray Exposure > TMJ Close positioning > Align Laser Beam > X-ray Exposure



Clean the chin rest and bite block with ethanol and wipe with a dry towel before the next patient.

TMJ Open Positioning

1. Remove the standard chinrest and insert the sinus chinrest into the equipment.
2. Insert the TMJ bite into the sinus chinrest.

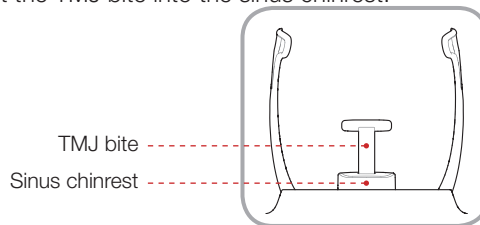

Clean the chin rest with ethanol and wipe with a dry towel before the next patient.

3. Use **Temple Support Open/Close** button on the control panel to widen temple supports.

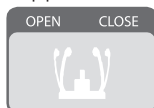

4. Guide the patient to the inside of the equipment.

6. Acquiring PANO images

5. Use the **Vertical Frame Up/Down** button or switch option to adjust the height of the equipment so the patient's chin reaches the chin rest.
6. Guide the patient to stand in the center of the equipment and direct them to remain in the position outlined below.
 - Two hands: Hold the handles of the equipment tightly.
 - Chest: Press against the equipment.
 - Two feet: Keep both feet close to the inside of the base.
 - Shoulders: Keep your shoulders relaxed and balanced.
 - Cervical Spine: Straighten your body and stand still.
7. Guide the patient to press the base of their nose (acanthion point) against the chin rest and tilt their head forward about -5° . At this point, make sure the patient's jaw does not touch the equipment.



If the jaw touches the equipment it is difficult to maintain the proper position to get good images.

Be careful the patient does not to touch the equipment with their jaw.

8. Direct the patient to maintain the posture as described below.
 - Mouth: After swallowing once, open your mouth as wide as possible.
 - Tongue: Touch the roof of your mouth.
 - Two eyes: Close your eyes.

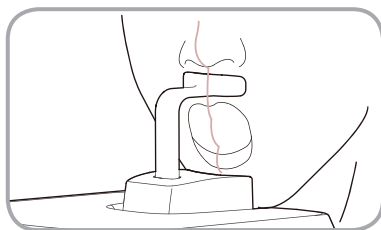

- As shown in the picture, the support unit of the integrated chin rest should touch the patient's acanthion point.
- Ask the patient to maintain their position until the operation is completed.

6. Acquiring PANO images

Laser Beam Positioning



Be careful not to shine the laser beam directly into the person's eyes.

Doing so may result in vision loss.



If the laser beam is not correctly positioned, distortion, where the image may be enlarged or reduced, or ghost shadows may occur and lower the image quality. Be sure to align the laser beam properly.

1. Align the vertical beam with the center of the face. (To prevent horizontal expansion of the image)
2. Align the horizontal beam in a straight line with the Frankfort line on the patient's face. Use the Horizontal Beam button on the control panel to position it. Check to see that the horizontal beam aligns with the patient's face horizontally.

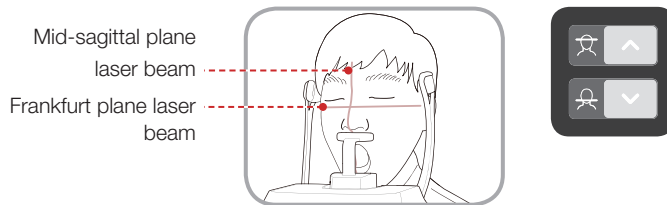

6. Acquiring PANO images

Finishing Patient Positioning

1. After checking the positions of the patient and the laser beam, click the **Temple Support Open/Close** button on the control panel to prevent the patient's head from moving.

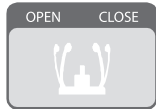

Make sure that the Temple Support is in **Close** position before clicking the **READY** button.

2. Click the **READY** button. The x-ray exposure has not started yet.
3. Now go to **6.3 X-ray Exposure** to begin operation.
4. When the Temple Support is open, guide the patient out of the equipment.

6.2.3 TMJ Close Mode

Acquire the TMJ Close image after the TMJ Open image has been acquired.



Steps for TMJ Mode

TMJ Open positioning > Align Laser Beam > X-ray Exposure > TMJ Close positioning > Align Laser Beam > X-ray Exposure



Correct posture reduces the shadow cast by the patient's cervical spine and allows for clear image acquisition.

6. Acquiring PANO images

TMJ Close Positioning

1. After TMJ Open image is acquired, a "Do you want to take the TMJ Close image continuously?" message is displayed. Press the Confirm button to begin TMJ Close Mode.
2. Guide the patient to the inside of the equipment.
3. Guide the patient to press the base of their nose (acanthion point) against the chin rest and tilt their head forward about -5° .
4. Direct the patient to maintain the posture as described below.
 - Mouth: Close your mouth
 - Tongue: Touch the roof of your mouth.
 - Two eyes: Close your eyes.

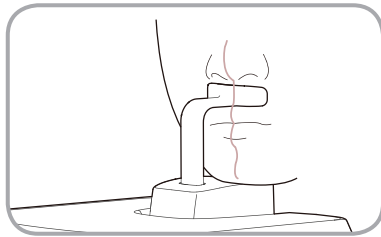

- As shown in the picture, the support unit of the integrated chin rest should touch the patient's acanthion point.
- Ask the patient to maintain their position until the operation is completed.

Laser Beam Positioning

This is the same as for TMJ Open mode.

Finishing Patient Positioning

This is the same as for TMJ Open mode.

6. Acquiring PANO images

6.2.4 Sinus Mode

Patient Positioning

1. Insert the sinus chinrest into the equipment.



Clean the chin rest with ethanol and wipe with a dry towel before the next patient.

2. Insert the Sinus/Edentulous bite into the sinus chinrest.

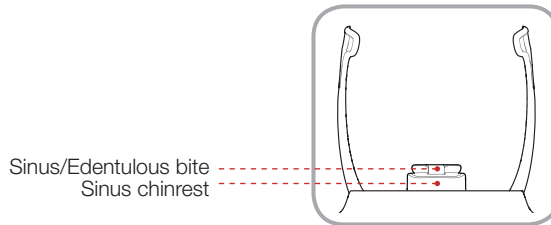

3. Use **Temple Support Open/Close** button on the control panel to widen temple supports.

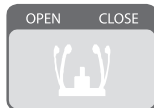

4. Guide the patient to the inside of the equipment.
5. Use the **Vertical Frame Up/Down** button or switch option to adjust the height of the equipment so the patient's chin reaches chin rest.

6. Acquiring PANO images

6. Guide the patient to stand in the center of the equipment and direct them to remain in the position outlined below.
 - Two hands: Hold the handles of the equipment tightly.
 - Chest: Press against the equipment.
 - Two feet: Keep both feet close to the inside of the base.
 - Shoulders: Keep your shoulders relaxed and balanced.
 - Cervical Spine: Straighten your body and stand still.
7. Direct the patient to maintain the posture as described below.
 - Head: Tilt the head back 10° - 15° .
 - Mouth: Close your mouth.
 - Tongue: Touch the roof of your mouth.
 - Two eyes: Close your eyes.

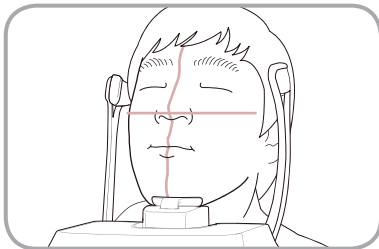

Ask the patient to maintain their position until the operation is completed.

6. Acquiring PANO images

Laser Beam Positioning



Be careful not to shine the laser beam directly into the person's eyes.

Doing so may result in vision loss.



If the laser beam is not correctly positioned, distortion, where the image may be enlarged or reduced, or ghost shadows may occur and lower the image quality. Be sure to align the laser beam properly.

1. Align the vertical beam with the center of the face. (To prevent horizontal expansion of the image)
2. Tilt the patient's head back 10° - 15° then align the horizontal beam with tip of the nose. Use the Horizontal Beam button on the control panel to position it.

Finishing Patient Positioning

1. After checking the positions of the patient and the laser beam, click the **Temple Support Open/Close** button on the control panel to prevent the patient's head from moving.

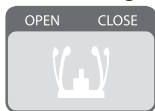

Make sure that the Temple Support is in **Close** position before clicking the **READY** button.

2. Click the **READY** button. The x-ray exposure has not started yet.
3. Now go to **6.3 X-ray Exposure** to begin operation.

6. Acquiring PANO images

6.3 X-ray Exposure

After the aligning the laser beam, the x-ray scan can begin.



The user must comply with the laws of the country regarding the usage of the medical equipment.



Direct the patient to close their eyes during operation.

To acquire optimized images, direct the patient to hold their breath and to not swallow. Also direct the patient to not move until the Temple support is open.

1. Direct the patient to close their eyes.
2. Close the door when leaving the x-ray room. Observe the patient during operation and check the imaging status.
3. Begin acquisition by pressing the exposure switch. Continue to press the exposure switch until the image has been acquired.

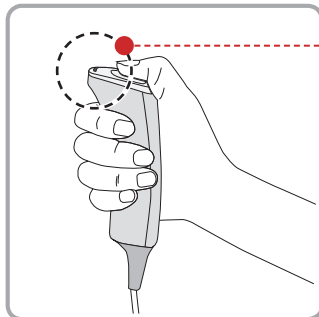

Yellow: X-ray On

4. Release the exposure switch when “Image capturing is completed” message appears on the screen.

During x-ray exposure, the status appears as follows.



- The exposure switch LED light is yellow.
- The exposure switch LED light on top of the equipment is yellow.
- An alert will sound to indicate that x-ray emission is currently underway.
- In the console software, the x-ray On in yellow changes.



6. Acquiring PANO images

6.4 Finishing Scan

1. Open the temple supports and guide the patient out of the equipment.
2. Remove the hygiene cover from the bite block.
3. Press  (**Return**) button to bring the Rotating Unit back to its initial position.

6.5 Confirming Image

Acquired images can be reconstructed and converted to DICOM format.

The exported images can be confirmed in EasyDent / EzDent-i.



Please refer to the EasyDent / EzDent-i User manual for more information.

1. The images are transferred to EasyDent / EzDent-i automatically.
2. The images are automatically saved if automatic save is configured in the basic settings. If automatic save is not configured in the basic settings, click the **Save to DB** button to save the images.
3. Double-click the image to confirm in the Patient list.



7 | Acquiring CEPH

| | | |
|-----|---------------------------------|----|
| 7.1 | Setting Exposure Parameters ... | 82 |
| 7.2 | Patient Positioning | 85 |
| 7.3 | X-ray Exposure..... | 96 |

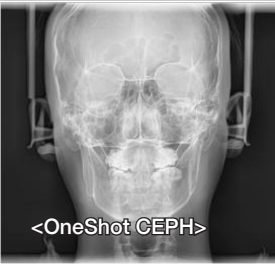
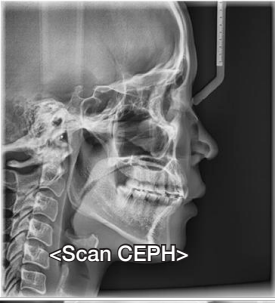

7. Acquiring CEPH images

To acquire images, **5. Getting Started** should be completed first. If **5. Getting Started** is not completed, return to that section and finish the step first.

CEPH Imaging Software

| Examination | Image | Description |
|-------------|---|--|
| PA |  <p data-bbox="491 865 632 890"><Scan CEPH></p> | <p>The radiation is directed from the posterior of the skull to the anterior.</p> <p>Use to examine cranial diseases, trauma and congenital malformations.</p> <p>Used to assess the growth of lateral side of the face. It is also useful to examine the ramus mandibulae, the posterior region of the third largest molar in the lower jaw, and the side wall of the maxillary sinus, and the frontal sinus, antrum ethmoidale, olfactory pits and optic disc pits.</p> <p>Measure the angles formed by the connecting lines between the cranial measurement points to further assess the growth of the facial region. It is widely used in Orthodontics and Oral and Maxillofacial Surgery.</p> |
| |  <p data-bbox="471 1126 650 1151"><OneShot CEPH></p> | |
| Lateral |  <p data-bbox="491 1474 632 1499"><Scan CEPH></p> | <p>Study craniofacial disease, trauma and congenital malformation and examine the soft tissue in the otorhinolaryngological area, sinus and hard palate.</p> <p>Measure the angles formed by the connecting lines between the cranial measurement points to further assess the growth of the facial region. It's widely used in Orthodontics and Oral and Maxillofacial Surgery.</p> |
| |  <p data-bbox="471 1696 650 1721"><OneShot CEPH></p> | |

7. Acquiring CEPH images

| Examination | Image | Description |
|-------------|--|--|
| SMV |  | <p>Use to study the base of the skull, horizontal angulation of the mandibular condylar axis, sphenoidal sinus, curvature of the lower jaw, side wall of the maxillary sinus, and zygomatic arch fractures. Also useful to study the inner and outer alar plates and holes at base of the skull.</p> |
| Waters View |  | <p>Use to study the frontal sinus, antrum ethmoidale, optic disc pit, frontozygomatic suture, nasal cavity, coronoid process between the upper jaw and zygomatic arch.</p> |
| CARPUS |  | <p>Use to assess hand bone age and compare with changes in the skull.</p> |

7. Acquiring CEPH images

7.1 Setting Exposure Parameters

Perform the following procedures to select the capture parameters for the specific patient and capture mode. Please refer to [4.3 Console Software](#) for the more information.

Steps for Configuring Imaging Conditions

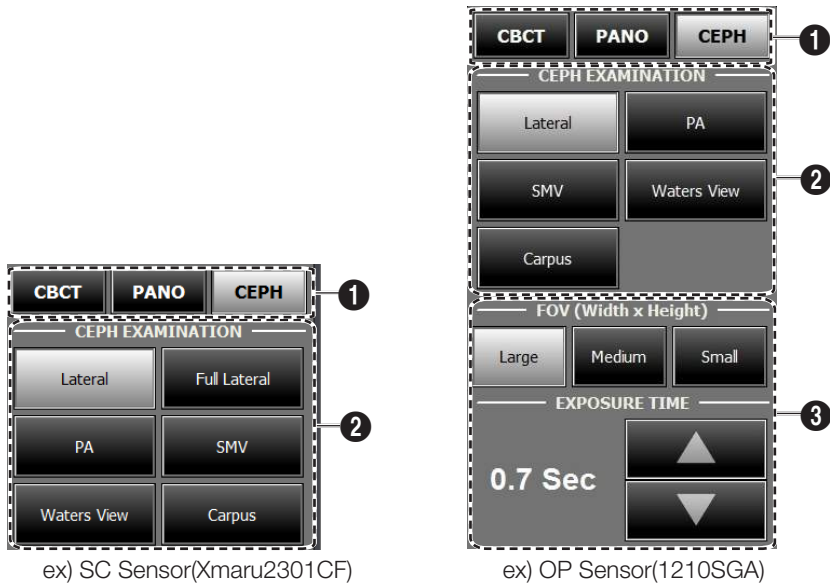

1. Click the **CEPH** button.
2. Select the examination program under **Ceph Examination**
3. (For One-shot CEPH only) Do the selections that follow.
 - **FOV Size:** Select the FOV size.

7. Acquiring CEPH images

| FOV | Details |
|--|---|
| Large : 12x10 (inches) : 30.48x25.40 (cm) | Full size |
| Medium : 9x10 (inches) : 22.86x25.40 (cm) | Region of the no interest of the rear part of the head is eliminated to minimize the X-ray exposure area. |
| Small : 8x8 (inches) : 20.32x20.32 (cm) | For Child |

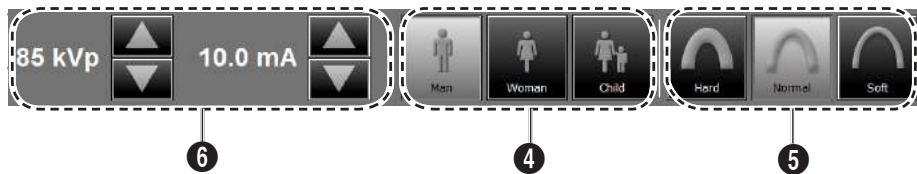

- The gender of the patient is selected automatically. When necessary, it can be selected directly.
- Select x-ray intensity.

7. Acquiring CEPH images

Depending on the circumference of the patient's head, X-ray intensity may be classified as Hard, Normal, or Soft :

Soft \leq Normal \leq Hard



| Age Group | Average head circumference | Range (cm) | Classification of head circumference |
|-----------|----------------------------|--------------|--------------------------------------|
| Child | 53 \pm 3 cm | > 53 \pm 3 | Hard |
| | | 53 \pm 3 | Normal |
| | | 53 \pm 3 < | Soft |
| Adult | 56 \pm 3 cm | > 56 \pm 3 | Hard |
| | | 56 \pm 3 | Normal |
| | | 56 \pm 3 < | Soft |

- The values of tube voltage and current are configured automatically according to the patient's gender and x-ray intensity. Click the arrow button to zoom in. The dose is adjustable by ± 1 kVp and ± 1 mA respectively.
- Once the configuration has been completed, click the **CONFIRM** button.



When you click **CONFIRM** button:

- The **READY** button will begin blinking to show that it has been activated.
- The **Scan Time** and **DAP** values will be shown on the Imaging Status Window.

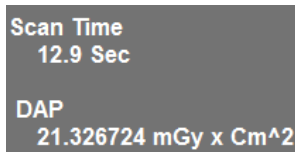

- Guide the patient to the equipment.

7. Acquiring CEPH images

7.2 Patient Positioning



- Have patients, especially pregnant women and children, wear a lead apron to protect them from residual radiation.
 - Be careful not to direct the laser beam into the patient's eyes. Doing so can result in a permanent loss of vision.
-



- Metal implants or bridges may reduce the quality of the images.
 - If the laser beam is not correctly positioned, distortion, where the image may be enlarged or reduced, or ghost shadows may occur and lower the image quality so please be careful.
 - Ensure that the nasal positioner left unfolded, before adjusting the ear rods in the proper direction.
-



Correct positioning is an important factor in capturing the best possible image.



Although the illustrations and explanations on patient's posture and device usage are based on the OS / OP models (one shot-type sensor), those for the SC (scan type) model should be the same.

7. Acquiring CEPH images

Getting Prepared

1. Ask the patient to remove all the metal objects (glasses, earrings, hair pins, braces, false teeth). Metal objects may induce ghost images and lower the image quality.
2. Ask the patient to wear a lead apron to protect them from residual radiation.
3. Use the **Vertical Frame Up/Down** button or switch option to adjust the equipment to match the height of the patient.



7.2.1 Lateral / Full Lateral Mode



Full Lateral mode is available for SCAN CEPH model only.

1. Turn the CEPH ear rods to **Lateral** mode position as shown in the figure.



2. Leave enough space between the ear rods.

7. Acquiring CEPH images

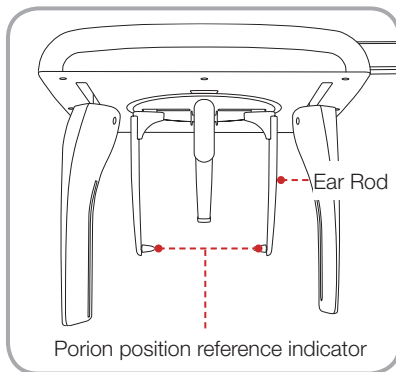

Use the Porion position reference indicator that appears in the acquired image to easily confirm the location of Porion.

3. Guide the patient to the CEPH unit.
4. Direct the patient to relax their neck and shoulders and stand upright.
5. Use the **Vertical Frame Up/Down** button or switch option to adjust the height of the CEPH Unit to approximately match the height of the patient.
6. Align the ear rods with the patient's ears properly so their head does not move during operation. And align the nasal positioner with the patient's nasion by adjusting its height.

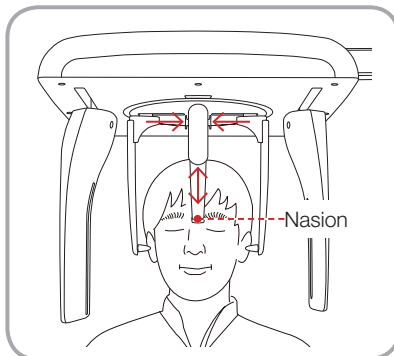

After adjusting the height of the column, align the ear rods and nasal positioner with the patient.

7. Align horizontally so the patient's Frankfort line is parallel with the floor.

7. Acquiring CEPH images

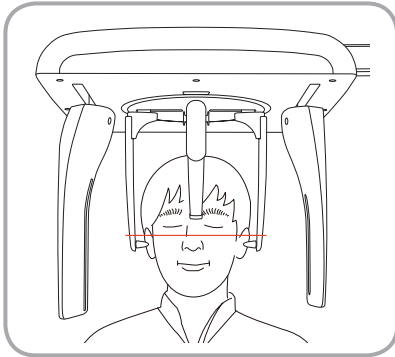

8. Direct the patient to swallow first before closing their mouth and to remain in their current position until image acquisition is complete.
9. Click the **READY** button. The x-ray exposure has not started yet.
10. Now go to **7.3 X-ray Exposure** to begin operation.

7. Acquiring CEPH images

7.2.2 PA mode

1. Turn the CEPH ear rods to **PA** mode position as shown in the figure.



2. Fold the nasal positioner up. The nasal positioner is not used in Frontal mode.
3. Guide the patient to the CEPH unit.
4. Ask the patient to stand upright facing the sensor. Make sure that the patient's shoulders are level and that his/her neck is relaxed.

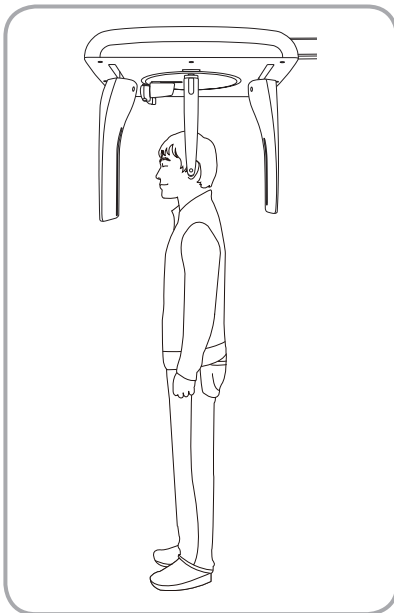

7. Acquiring CEPH images

5. Use the **Vertical Frame Up/Down** button or switch option to adjust the height of the CEPH Unit to approximately match the height of the patient.
6. During operation, properly align the ear rods with the patient's ears so their head does not move.



After adjusting the height of the column, align the ear rods with the patient.

7. Align horizontally so the patient's Frankfort line is parallel with the floor.

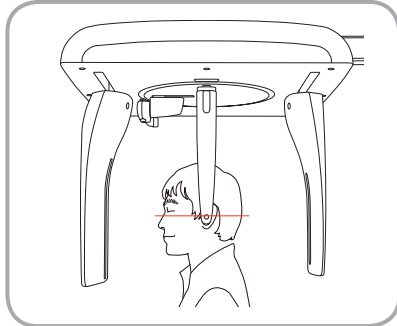

8. Direct the patient to swallow first before closing their mouth and to remain in their current position until image acquisition is complete.
9. Click the **READY** button. The x-ray exposure has not started yet.
10. Now go to [7.3 X-ray Exposure](#) to begin operation.

7. Acquiring CEPH images

7.2.3 SMV Mode

1. Turn the CEPH ear rods to **SMV** mode position as shown in the figure.



2. Fold the nasal positioner up. The nasal positioner is not used in SMV mode.
3. Guide the patient to the CEPH unit.
4. Guide the patient to face the X-ray tube and stand upright.

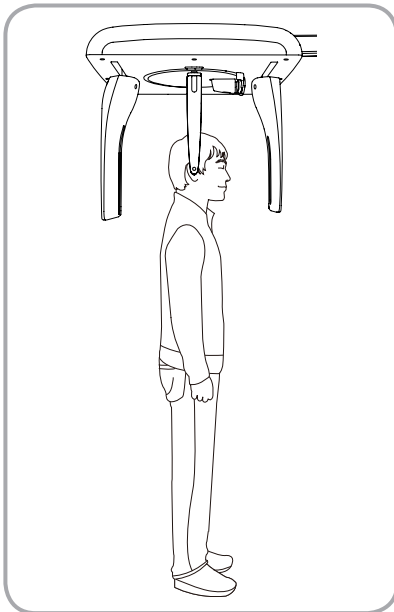

7. Acquiring CEPH images

5. Use the Vertical Frame Up/Down button or switch (option) to adjust the height of the CEPH Unit to match the height of the patient.
6. During operation, properly align the ear rods with the patient's ears so their head does not move.



After adjusting the height of the column, align the ear rods with the patient.

7. Carefully tilt the patient's head back and adjust so their Frankfort line is vertical with the floor.
8. Direct the patient to swallow first before closing their mouth and to remain in their current position until image acquisition is complete.

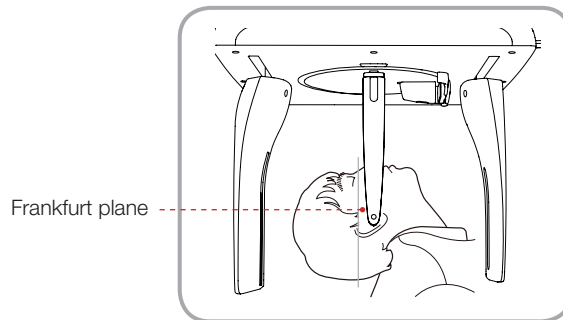

9. Click the **READY** button. The x-ray exposure has not started yet.
10. Now go to [7.3 X-ray Exposure](#) to begin operation.

7. Acquiring CEPH images

7.2.4 Waters View Mode

1. Turn the CEPH ear rods to **Waters View** mode position as shown in the figure.



2. Fold the nasal positioner up. The nasal positioner is not used in Waters View mode.
3. Guide the patient to the CEPH unit.
4. Ask the patient to stand upright facing the sensor. Make sure that the patient's shoulders are level and that his/her neck is relaxed.
5. Use the **Vertical Frame Up/Down** button or switch option to adjust the height of the CEPH Unit to approximately match the height of the patient.
6. During operation, properly align the ear rods with the patient's ears so their head does not move.



After adjusting the height of the column, align the ear rods with the patient.

7. Acquiring CEPH images

7. Direct the patient to swallow and close their mouth, and guide the patient's head back 30° - 40°. Direct the patient to remain in the current position until image acquisition is complete.

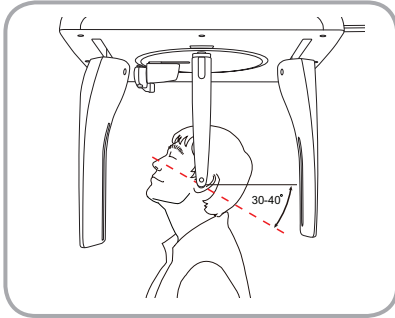

8. Click the **READY** button. The x-ray exposure has not started yet.
9. Now go to **7.3 X-ray Exposure** to begin operation.

7.2.5 CARPUS Mode

■ Installing the Carpus Plate

1. Align the end of the nasal positioner to the carpus plate groove so it is attached to the nasal positioner.

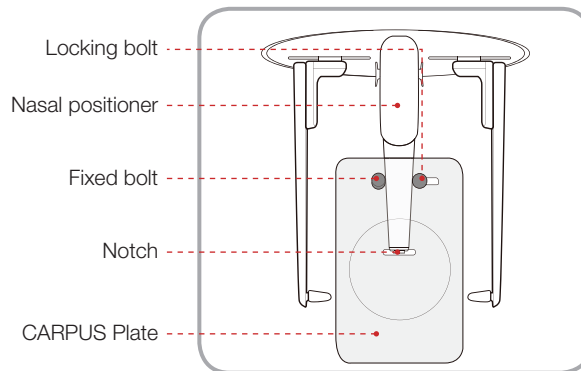

7. Acquiring CEPH images

2. Pull the locking bolt to the left (in the direction of the nasal positioner). After securing the bolt in place, turn to the left to tighten.

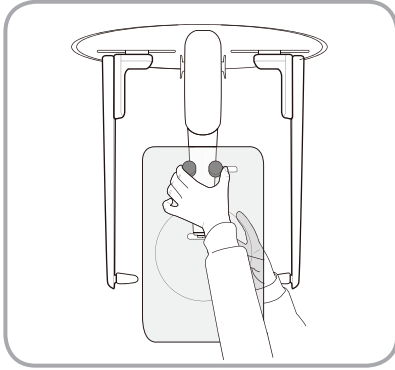

3. Confirm that carpus plate is safely mounted.

■ Patient Positioning

1. Have the patient spread their right hand and locate the carpus plate. Make sure they do not to bend their fingers.

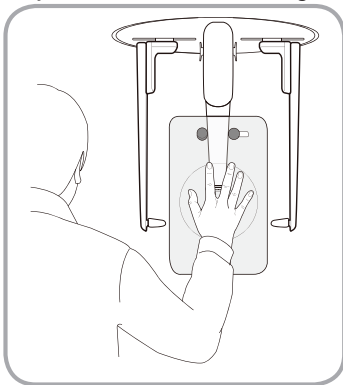

2. Ask the patient to close their eyes and stand still until the image acquisition is completed.



Make sure the patient's fingers do not to block the positioner. Doing so may reduce the image quality.

3. Click the **READY** button. The x-ray exposure has not started yet.

7. Acquiring CEPH images

4. Now go to **7.3 X-ray Exposure** to begin operation.

7.3 X-ray Exposure

After alignment, the x-ray scan can begin.



The user must comply with the laws of the country regarding the usage of the medical equipment.



Direct the patient to close their eyes during operation.

To acquire optimized images, direct the patient to hold their breath and to not swallow. Also direct the patient to not move.

1. Direct the patient to close their eyes.
2. Close the door when leaving the x-ray room. Observe the patient during operation and check the imaging status.
3. Begin acquisition by pressing the exposure switch. Continue to press the exposure switch until the image has been acquired.

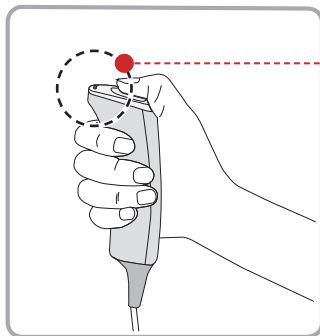

Yellow: X-ray On

4. Release the exposure switch when “Image capturing is completed” message appears on the screen.

7. Acquiring CEPH images

During x-ray exposure, the status appears as follows.



- The exposure switch LED light is yellow.
- The exposure switch LED light on top of the equipment is yellow.
- An alert will sound to indicate that x-ray emission is currently underway.
- In the Console Software, the x-ray On in yellow changes.



7.4 Finishing Scan

1. Leave enough spaces between the ear rods.
2. Fold the nasal positioner up.
3. Guide the patient out of the equipment.

7.5 Confirming Image

Acquired images can be reconstructed and converted to DICOM format.

The exported images can be confirmed in EasyDent / EzDent-i.



Please refer to the EasyDent / EzDent-i User manual for more information.

1. The images are transferred to EasyDent / EzDent-i automatically.
2. The images are automatically saved if automatic save is configured in the basic settings. If automatic save is not configured in the basic settings, click the **Save to DB** button to save the images.
3. Double-click the image to confirm in the Patient list.

8

7.4 Finishing Scan.....97

7.5 Confirming Image.....97

8.1 Setting Exposure Parameters100

8.2 Patient Positioning103

8.3 X-ray Exposure.....108

8.4 Finishing Scan.....110

8.5 Confirming Image.....110

8. Acquiring CBCT Images

To acquire images, **5. Getting Started** should be completed first. If **5. Getting Started** is not completed, return to that section and finish the step first.

8.1 Setting Exposure Parameters

Perform the following procedures to select the capture parameters for the specific patient and capture mode. Please refer to **4.3 Console Software** for more information.

Steps for Configuring Imaging Conditions

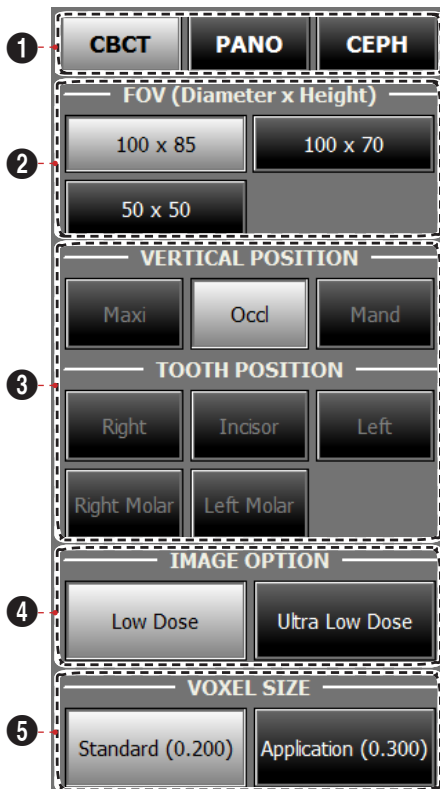

1. Click **CBCT**.
2. Select **FOV Size**.



- 100 x 85: for Adult
- 100 x 70: for Child
- 50 x 50(optional): for specific tooth

8. Acquiring CBCT Images

3. (For FOV 50 x 50 only, optional) Select the ROI(Region of Interest) to be captured under VERTICAL POSITION and TOOTH POSITION.
4. Select Image Option. (Select Low Dose or Ultra Low Dose)

Ultra low dose mode produces 50%~60% lower dose than Low dose mode during exposure.



| Mode | DAP[mGy · cm ²] | Remarks |
|----------------|-----------------------------|---|
| Low dose | 650 | Model: PaX-i3D Smart (PHT-30LFO) Gender: Man X-ray intensity: Normal |
| Ultra low dose | 260 | |

5. Select Voxel Size. (Select Standard or Application)

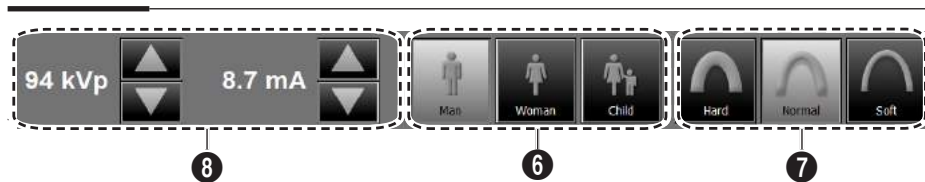

6. The gender of the patient is selected automatically. When necessary, it can be selected directly.
7. Select X-ray intensity.

8. Acquiring CBCT Images

Depending on the circumference of the patient's head, X-ray intensity may be classified as Hard, Normal, or Soft :

Soft \leq Normal \leq Hard



| Age Group | Average head circumference | Range (cm) | Classification of head circumference |
|-----------|----------------------------|--------------|--------------------------------------|
| Child | 53 \pm 3 cm | > 53 \pm 3 | Hard |
| | | 53 \pm 3 | Normal |
| | | 53 \pm 3 < | Soft |
| Adult | 56 \pm 3 cm | > 56 \pm 3 | Hard |
| | | 56 \pm 3 | Normal |
| | | 56 \pm 3 < | Soft |

- The values of tube voltage and current are configured automatically according to the patient's gender and x-ray intensity. Click the arrow button to zoom in. The dose is adjustable by ± 1 kVp and ± 0.1 mA respectively.
- Once the configuration has been completed, click the **CONFIRM** button.



When you click **CONFIRM** button:

- The **READY** button will begin blinking to show that it has been activated.



- The Rotating unit will move to its initial scanning position.
- Two laser beams will be activated to make patient positioning easier.
- The **Scan Time** and **DAP** values will be shown on the Imaging Status Window.

8. Acquiring CBCT Images

Scan Time
18.0 Sec

DAP
646.447615 mGy x Cm²

10. Guide the patient to the equipment.

8.2 Patient Positioning



- Have patients, especially pregnant women and children, wear a lead apron to protect them from residual radiation.
 - Be careful not to direct the laser beam into the patient's eyes. Doing so can result in a permanent loss of vision.
-



- Metal implants or bridges may reduce the quality of the images.
 - If the laser beam is not correctly positioned, distortion, where the image may be enlarged or reduced, or ghost shadows may occur and lower the image quality so please be careful.
-



Correct posture reduces the shadow cast by the patient's cervical spine and allows for clear image acquisition.



In general, images are acquired when the patient is standing. In special cases, a chair without a backrest (stool) may be used. Do not obstruct the laser beam or the operation of the equipment with the chair.

Getting prepared

8. Acquiring CBCT Images

1. Ask the patient to remove all the metal objects (glasses, earrings, hair pins, braces, false teeth). Metal objects may induce ghost images and lower the image quality.
2. Ask the patient to wear a lead apron to protect them from residual radiation.
3. **Use the Vertical Frame Up/Down button or switch option to adjust the equipment to match the height of the patient.**

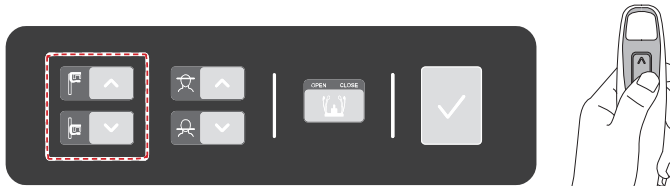

■ Patient Positioning

1. Insert the bite block into the chin rest then cover with a sanitary vinyl cover.

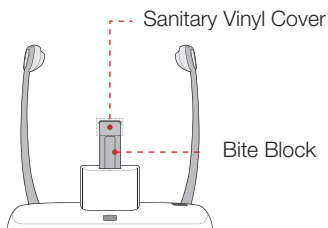

The sanitary vinyl cover is for single use only. It should be replaced after each patient. Be sure to use the approved vinyl cover.



Clean the chin rest and bite block with ethanol and wipe with a dry towel before the next patient.

8. Acquiring CBCT Images

2. Use **Temple Support Open/Close** button on the control panel to widen temple supports.

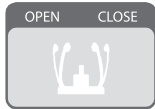

3. Guide the patient to the inside of the equipment.
4. Use the Vertical Frame Up/Down button or switch option to adjust the height of the equipment so the patient's chin reaches the chin rest.
5. Guide the patient to stand in the center of the equipment and direct them to remain in the position outlined below.
 - Two hands: Hold the handles of the equipment tightly.
 - Chest: Press against the equipment.
 - Two feet: Keep both feet close to the inside of the base.
 - Shoulders: Keep your shoulders relaxed and balanced.
 - Cervical Spine: Straighten your body and stand still.

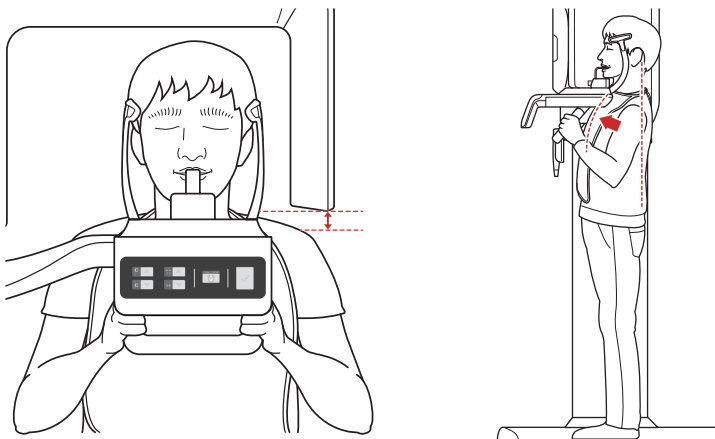

8. Acquiring CBCT Images

- Make sure that there is no interference between the sensor housing and the shoulder.
- Ask the patient to loosen his/her hair if it is tied back.

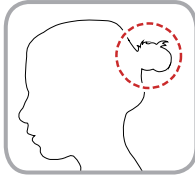

-
6. Direct the patient to correctly bite into the bite block groove with their front teeth.
 7. Direct the patient to maintain the posture as described below.

- Mouth: Close your mouth.
- Tongue: Touch the roof of your mouth.
- Two eyes: Close your eyes.

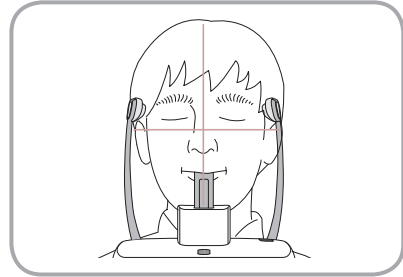

8. Acquiring CBCT Images

Correct posture reduces the shadow cast by the patient's cervical spine and allows for clear image acquisition. During image acquisition, direct the patient to maintain the posture as described below.



- Two hands: Hold the handles of the equipment tightly.
- Chest: Press against the equipment.
- Two feet: Keep both feet close to the inside of the base.
- Shoulders: Keep your shoulders relaxed and balanced.
- Cervical Spine: Straighten your body and stand still.
- Mouth: Bite the bite block and close your mouth.
- Tongue: Touch the roof of your mouth.
- Two eyes: Close your eyes.

Ask the patient to maintain their position and to not move until the image acquisition is completed.

Laser Beam Positioning



Be careful not to shine the laser beam directly into the person's eyes. Doing so may result in vision loss.



If the laser beam is not correctly positioned, distortion, where the image may be enlarged or reduced, or ghost shadows may occur and lower the image quality. Be sure to align the laser beam properly.

8. Acquiring CBCT Images

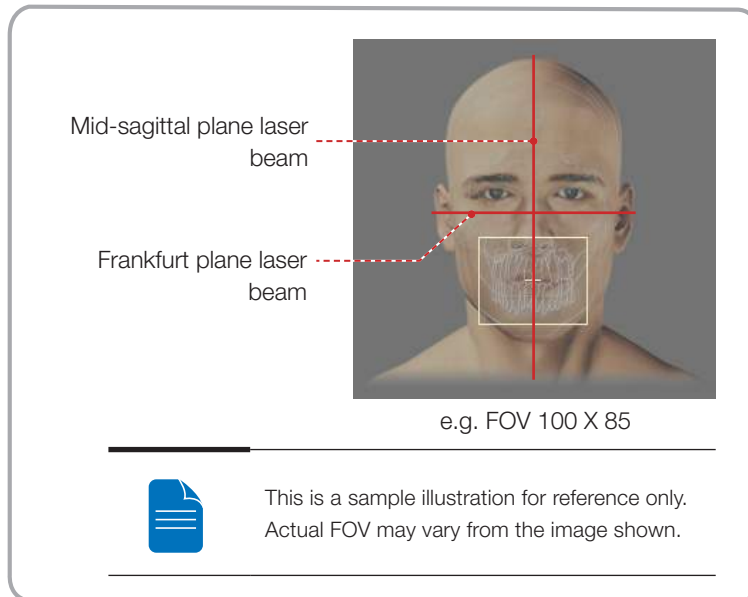

1. Align the Mid-sagittal plane laser beam with the center of the face. (To prevent horizontal expansion of the image)
2. Align the Frankfurt plane laser beam in a straight line with the Frankfurt line on the patient's face. Use the Frankfurt plane laser beam button on the control panel to position it. Check to see that the Frankfurt plane laser beam aligns with the patient's face horizontally.

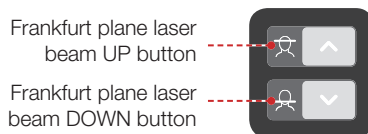

Finishing Patient Positioning

1. After checking the positions of the patient and the laser beam, click the **Temple Support Open/Close** button on the control panel to prevent the patient's head from moving.

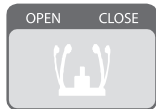

2. Click the **READY** button. The x-ray exposure has not started yet.
3. Now go to **8.3 X-ray Exposure** to begin operation.

8.3 X-ray Exposure

After alignment, the x-ray scan can begin.



The user must comply with the laws of the country regarding the usage of the medical equipment.



Direct the patient to close their eyes during operation.

To acquire optimized images, direct the patient to hold their breath and to not swallow. Also direct the patient to not move until the Temple support is open.

1. Direct the patient to close their eyes.
2. The user closes the door when leaving the X-ray room.
Observe the patient during operation and check the imaging status.

8. Acquiring CBCT Images

3. Begin acquisition by pressing the exposure switch.
Continue to press the exposure switch until the image has been acquired.

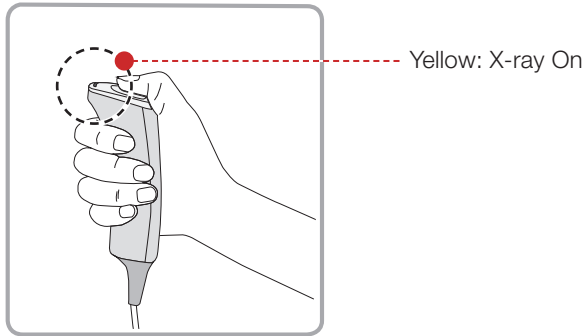

4. Release the exposure switch when “Image capturing is completed” message appears on the screen.

During x-ray exposure, the status appears as follows.



- The exposure switch LED light is yellow.
- The exposure switch LED light on top of the equipment is yellow.
- An alert will sound to indicate that x-ray emission is currently underway.
- In the console software, the x-ray On in yellow changes.



8. Acquiring CBCT Images

8.4 Finishing Scan

1. Open the temple supports and guide the patient out of the equipment.
2. Remove the sanitary vinyl cover from the bite block.
3. Press  (**Return**) button to bring the Rotating Unit back to its initial position.

8.5 Confirming Image

Acquired images can be reconstructed and converted to DICOM format.

The exported images can be confirmed in EasyDent / EzDent-i.



Please refer to the EasyDent / EzDent-i User manual for more information.

1. The images are transferred to EasyDent / EzDent-i automatically.
2. The images are automatically saved if automatic save is configured in the basic settings. If automatic save is not configured in the basic settings, click the **Save to DB** button to save the images.
3. Double-click the image to confirm in the Patient list. The Ez3D plus / Ez3D-i will run automatically.

8. Acquiring CBCT Images



9 | Troubleshooting

9. Troubleshooting

If a problem occurs while operating this equipment, perform the corresponding troubleshooting measure outlined in the table below. If the problem persists, please contact our customer support staffs.

If the device is not moving

| Cause | Solution |
|-------------------------------|--|
| Power failure | Check the equipment's power supply. |
| Initialization status | Wait until the equipment has initialized and then try again. |
| Control PC connection failure | Check the connection status of Communication Port(Optic) which connects the PC to the equipment. |

If the exposure switch is not functioning

| Cause | Solution |
|--------------|--|
| Ready status | Check whether it is ready for capturing at the console software. |

If imaging cannot be performed

| Cause | Solution |
|-----------------------|---|
| Initialization status | Wait until the equipment has initialized and then try again. If this problem persists, restart the equipment. |

9. Troubleshooting

If the laser beam has shut off and patient alignment cannot be performed

| Cause | Solution |
|---|---|
| The time allotted for patient alignment has expired | Press the laser beam button to turn on the lasers and then carry out patient alignment. |



If a problem occurs during image acquisition, press the red emergency stop switch to immediately stop all moving parts and cut off all power to the equipment's electrical components. You may then safely release the patient from the equipment.



Do not allow any liquids in the vicinity of the machine as moisture may cause extensive damage to this equipment's electrical components.

10 | Cleaning and Maintenance

| | |
|------------------------|-----|
| 10.1 Cleaning..... | 116 |
| 10.2 Maintenance | 117 |

10. Cleaning and Maintenance



Always turn off the power to the equipment and disconnect it from the power outlet before cleaning.

10.1 Cleaning

- Thoroughly clean areas of the equipment which come into contact with the patient, such as the handle frame, chin support and bite block.
- Do not use spray cleaners or solvents as they could enter the equipment and damage to the electrical components or cause a fire.
- Do not use abrasive liquids such as acetone, gas, or oil, which could corrode the surface of the equipment.
- Do not use cleaning products which contain silicon as they could potentially damage the equipment's electrical components.

The following table summarizes the standard cleaning procedures to be performed by the operator.

| Components | Cleaning Process |
|-----------------------------------|--|
| Bite Block | Clean with ethanol and gently wipe with a dry towel before the next patient. |
| Temple Supports | Clean with ethanol and gently wipe with a dry towel before the next patient. |
| Chin rest (Normal, Sinus, TMJ) | Clean with ethanol and gently wipe with a dry towel before the next patient. |
| Computer and peripherals | Follow the manufacturers' instructions found in the accompanying manuals. |
| Outer covers of equipment | Wipe the unit with a dry cloth at the end of each day. |



Do not use cleaning agents in aerosol or spray form directly on the surface of the equipment.

10. Cleaning and Maintenance

10.2 Maintenance

VATECH requires periodic constancy tests to ensure image quality and the safety for the patient and operator.

Only VATECH authorized technicians can perform inspection and service of this equipment. For the technical assistance, contact VATECH service center or your local VATECH representative.

10.2.1 Regular Maintenance



- Always turn off the equipment before performing any maintenance.
 - Never remove equipment covers. There are no repairable parts inside.
 - The only part that can be replaced by the user is the input fuses, which must comply with the manufacturer's specification.
 - In order to safeguard against fire, only replace fuses with fuses of the same type and range.
-



- There are no user serviceable parts inside this equipment.
 - If servicing is required, please contact the VATECH service center or your local VATECH representative.
-

- Do not use force to unplug cables.
- Do not expose the equipment or components in an area which is susceptible to water or humidity.
- Do not expose the equipment in an area which subject to temperature extremes, poor ventilation, direct sun light, dust, salt, etc.
- Keep all detachable components well organized and clean.
- Make sure that the equipment is well grounded.
- Never try to modify this equipment, including the wires or cables. Modifying this equipment may damage it beyond repair.

10. Cleaning and Maintenance

10.2.2 Maintenance Task Checklis

| Maintenance Tasks | Maintenance period |
|---|--------------------|
| Before operation, ensure that the equipment is clean and ready for use. Make sure that all parts which come into contact with the patient have been cleaned. | Daily |
| After using the equipment, make sure that the main power switch has been turned off. | Daily |
| Ensure that the equipment is firmly plugged into a dedicated power source. | Daily |
| Ensure that the plug and power cord are not hot. | Daily |
| Confirm that the yellow (exposure) indicator lamp turns on when the exposure switch is pressed. Ensure that the yellow (exposure) indicator light remains on for the entire duration of the exposure. | Daily |
| Ensure that the power cable is not kinked, broken, exposed and that it is free of all other defects. | Daily |
| Confirm that activating the emergency stop switch ceases the unit's operation. Pressing the emergency stop switch should stop all equipment movements and X-ray emission. | Weekly |
| Ensure that all visible labels are intact and legible. | Weekly |
| Check for possible wear or damage to the exposure switch cable. | Monthly |
| Confirm that the audio message is audible throughout the duration of the exposure. | Monthly |



Please refer to the “Constancy Test Requirement” for documents about the image quality inspection methods.



11 | Disposing of the Unit

11. Disposing of the Unit

In order to reduce environmental contamination, this equipment is designed to be as safe as possible to use and dispose of. Many components of this equipment, except for some like X-ray tube, are environment-friendly and can be recycled.

All parts and components which contain hazardous materials must be disposed in accordance with disposal regulations (IEC 60601-1 6.8.2 j).

| Part | Material | Recyclable | Waste Disposal Site | Hazardous waste; Needs Separate Collection |
|------------------------|----------------------------------|------------|---------------------|--|
| Frame and covers | Aluminum and plastics | • | | |
| Motors | | • | | |
| Circuit boards | | • | | |
| Cables and transformer | Copper | • | | |
| | Steel | • | | |
| | Oil | | • | |
| Packing | Wood | • | | |
| | Cardboard | • | | |
| | Paper | • | | |
| X-ray tube | | | | • |
| Sensor head | Return the sensor head to VATECH | | | |
| Other parts | | | • | |



This dental equipment shall not be disposed of as domestic garbage materials.



Please clean the equipment before disassembling it and disposing of its parts.



Please observe all regulations relevant to the disposal of waste in your country.

12 | Technical Specifications

- 12.1 Mechanical Specifications122
- 12.2 Technical Specifications127
- 12.3 Electrical Specifications131
- 12.4 Environmental Specifications131

12. Technical Specifications

12.1 Mechanical Specifications

■ Image Magnification

| Mode | FDD (mm) | FOD (mm) | ODD (mm) | Magnification |
|------|----------|----------|----------|---------------|
| CBCT | 600 | 428.57 | 171.43 | 1.4 CONSTANT |
| PANO | 600 | 477.7 | 122.3 | 1.26 CONSTANT |
| CEPH | 1745 | 1524 | 221 | 1.14 CONSTANT |

- **FDD:** Focal Spot to Detector Distance
- **FOD:** Focal Spot to Object Distance
- **ODD:** Object to Detector Distance ($ODD = FDD - FOD$)
- **Magnification** = FDD / FOD

12. Technical Specifications

Dimension

- Without cephalometric unit & Non-Base type

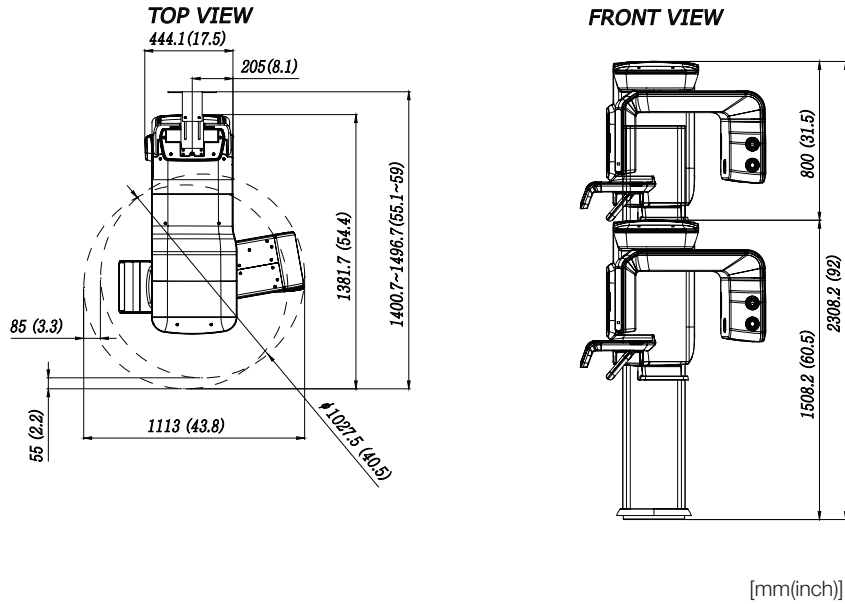

- Without cephalometric unit & Base type

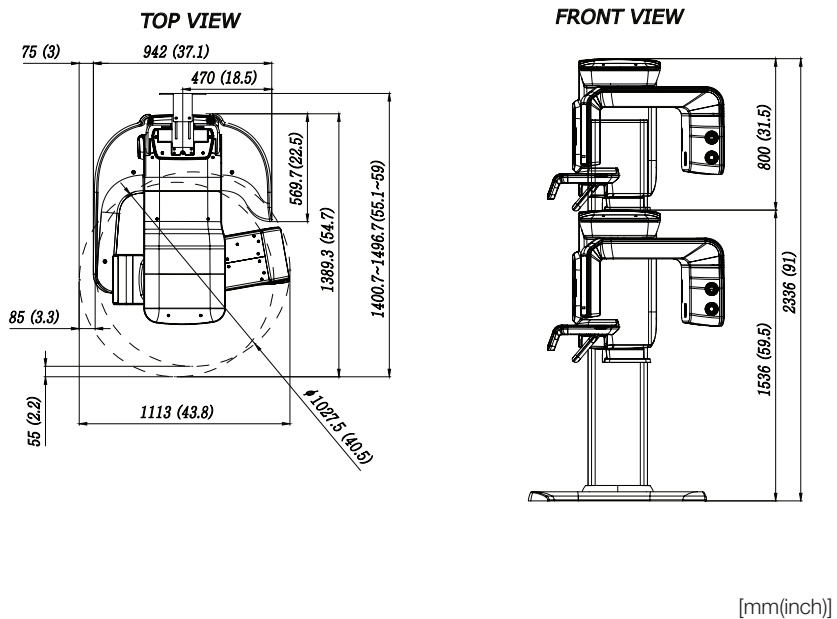

12. Technical Specifications

- With cephalometric unit & Non-Base type

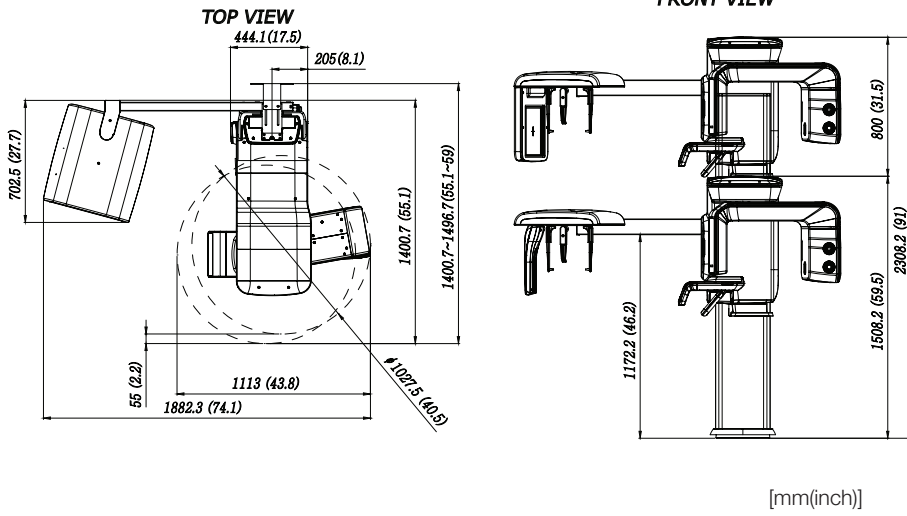

- With cephalometric unit & Base type

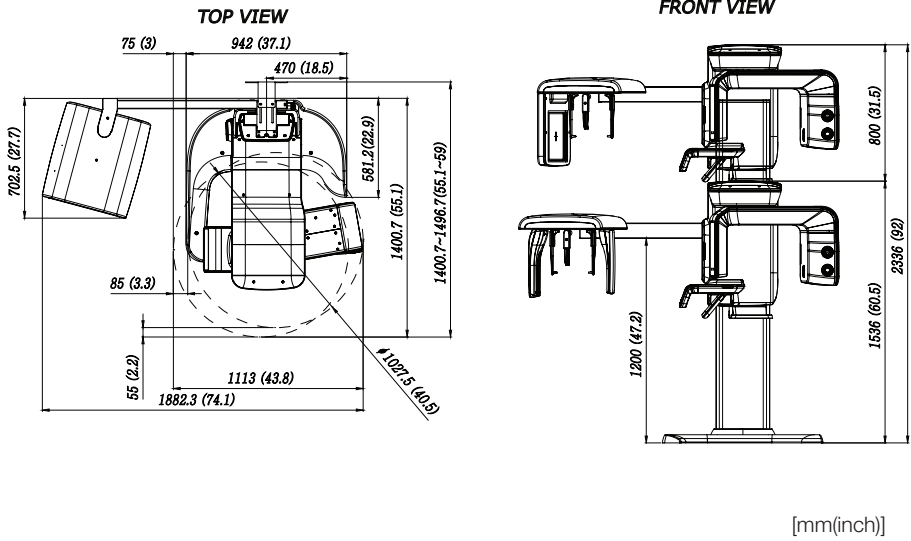

12. Technical Specifications

■ Common Dimensions(Non-Base type)

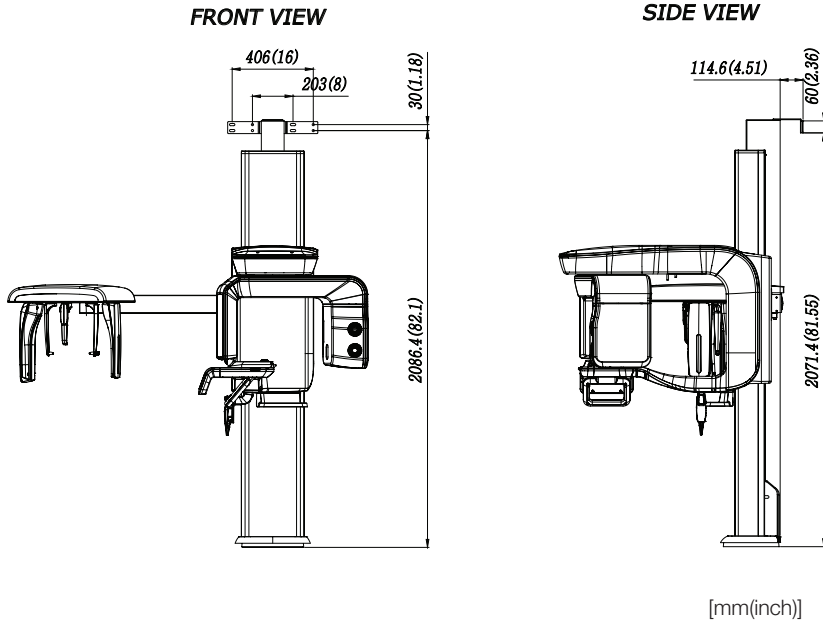

■ Common Dimensions(Base type)

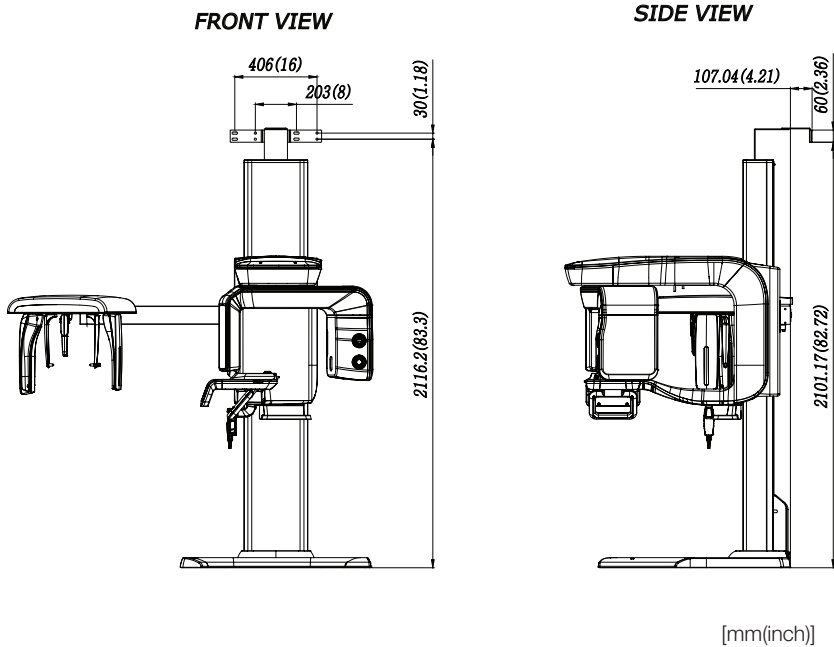

12. Technical Specifications

| Item | Description | | |
|-------------------------------------|-------------------------------|-----------------------------------|--------------------|
| Weight | without CEPH unit | Without Base | 167 kg (368.2 lbs) |
| | | with Base | 220 kg (485 lbs) |
| | with CEPH unit (scan type) | Without Base | 202 kg (445.3 lbs) |
| | | with Base | 255 kg (562.2 lbs) |
| | with CEPH unit (oneshot type) | Without Base | 212 kg (467.4 lbs) |
| | | with Base | 265 kg (584.2 lbs) |
| Total Height | | Max. 2336 mm (92 inch) | |
| Vertical Column Movement | | Max. 700 mm (Max. 27.6 inch) | |
| Dimension (Length x Width x Height) | without CEPH unit | 1113 (L) x 1389(W) x 2336 (H) mm | |
| | | 43.8(L) x 54.7(W) x 92(H) inch | |
| | with CEPH unit (scan type) | 1882 (L) x 1400 (W) x 2336 (H) mm | |
| | | 74.1(L) x 55.1(W) x 92(H) inch | |
| | with CEPH unit (oneshot type) | 1882 (L) x 1400 (W) x 2336 (H) mm | |
| | | 74.1(L) x 55.1(W) x 92(H) inch | |
| Type of installation | | Base stand / Wall mount | |

12. Technical Specifications

12.2 Technical Specifications

X-Ray Generator

| Item | Description | |
|-------------------------|----------------------------|--|
| Model | DG-07C11T2 | |
| Rated output power | 1.6KW (1sec) | |
| High Voltage Generator | Type | Inverter Type |
| | Normal / Pulse | 60 ~ 99 kV (Max. 99kV 10mA) |
| | | 4 ~ 16 mA (Max 75kV 16mA) |
| | | 0.5 ~ 20 sec |
| | Cooling | Automatically controlled / Protect $\geq 60^{\circ}\text{C}$ Cooling Fan : Optional |
| | Added Filtration (mmAl) | 1.5 mm Al eq. |
| Total Filtration (mmAl) | 2.8 mm Al eq. | |
| X-ray tube | Model Name | D-052SB(Stationary Anode Type) |
| | Manufacturer | Toshiba |
| | Focal Spot (mm) | 0.5mm x 0.5mm (IEC60336) |
| | Inherent Filtration (mmAl) | At least 0.8 mm Al eq. at 50 kV |
| | Target angle | 5 ° |
| | X- ray Coverage | 95 x 380 mm at SID 550 mm |
| | Anode Heat Content | 35 kJ |
| | Duty Cycle | 1:60 or more (Exposure time : Interval time) |
| Weight | INV-11 Inverter | 1.35 kg |
| | DG-07CT2(H-Type) Monotank | 12.5 kg |

12. Technical Specifications

D-052SB

DC (Center Grounded)

Constant potential high-voltage generator

Nominal Focus Spot Value: 0.5

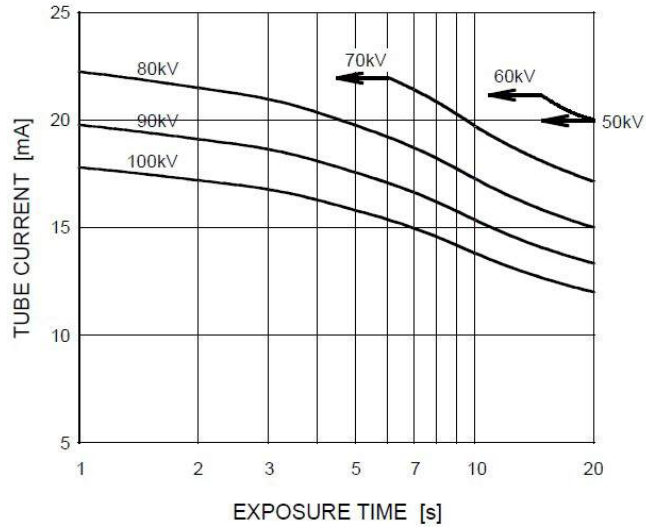

Emission & Filament Characteristics

Constant potential high-voltage generator

Nominal Focus Spot Value: 0.5

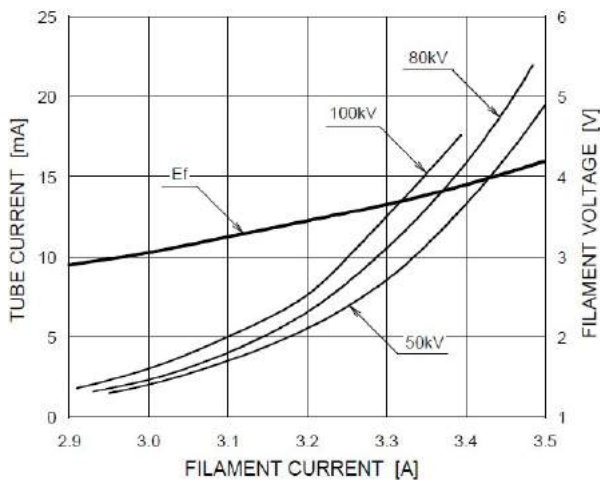

Anode Thermal Characteristics

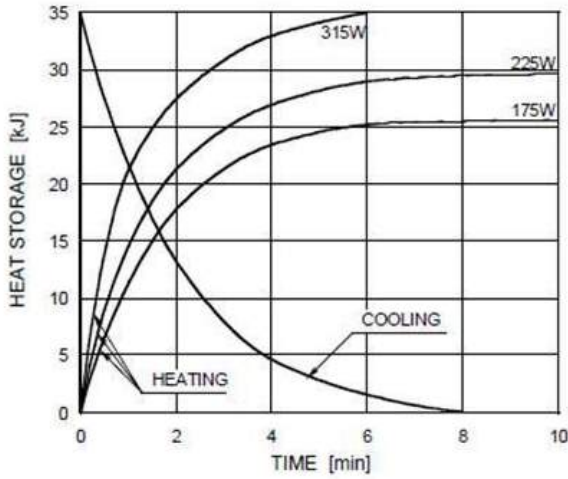

X-ray Housing Assembly Tube Characteristics

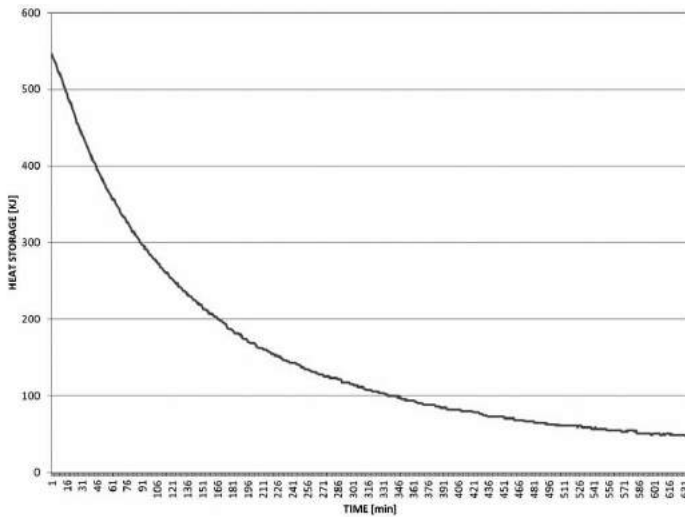

12. Technical Specifications

Detector Specifications

| Item | Description | |
|------------------|---------------------------------|--------------|
| | Panoramic | CBCT |
| Model | Xmaru1404CF | |
| Detector type | CMOS Photodiode Array | |
| Pixel size (μm) | 198(4x4 binning) | |
| Active area (mm) | 135.8 x 5.94 | 135.8 x 36.4 |
| Frame rate (FPS) | 400 | 100 |
| A/D (bits) | 14 | |
| MTF | > 40% @1lp/mm > 8% @2.5lp/mm | |
| DQE | > 60% @~0lp/mm | |
| Dynamic Range | > 80dB | |
| Sensor size (mm) | 230 x 160 x 26 | |

| Item (CEPH) | Description | |
|------------------|---------------------------------|---|
| Model | Xmaru2301CF | 1210SGA |
| Detector type | CMOS Photodiode Array | Amorphous Silicon TFT with Scintillator |
| Pixel size (μm) | 100 | 127 |
| Active area (mm) | 5.9 x 230.4 | 260.1 x 325.1 |
| Frame rate (FPS) | 200 | 360 fph(frames per hour) |
| A/D (bits) | 14 | 14, 16 |
| MTF | > 30% @1lp/mm > 5% @2.5lp/mm | > 50% @1lp/mm |
| DQE | > 75% @~0lp/mm | > 36% @0.1lp/mm |

12. Technical Specifications

| Item (CEPH) | Description | |
|------------------|-------------------|----------------|
| Dynamic Rang | > 62dB | > 69dB |
| Sensor size (mm) | 251.2 x 69 x 27.1 | 402 x 364 x 32 |

12.3 Electrical Specifications

| Item | Description |
|----------------------|-------------------------|
| Power supply voltage | AC 100-240 V ± 10 % |
| Frequency | 50/60 Hz |
| Power rating | 2.2 kVA ± 10 % |

- The input line voltage depends on the local electrical distribution system.
- Allowable input voltage fluctuation requirement: ± 10 %.

12.4 Environmental Specifications

| | Item | Description |
|-----------------------|----------------------|----------------|
| During operating | Temperature | 10 ~ 35 °C |
| | Relative humidity | 30 ~ 75 % |
| | Atmospheric pressure | 860 ~ 1060 hPa |
| Transport and storage | Temperature | -10 ~ 60 °C |
| | Relative humidity | 10 ~ 75 % |
| | Atmospheric pressure | 860 ~ 1060 hPa |

13 | Appendices

| | |
|--|-----|
| 13.1 Recommended X-ray Exposure Table | 134 |
| 13.2 X-ray Dose Data | 137 |
| 13.3 Electromagnetic Compatibility (EMC) Information | 142 |
| 13.4 Acquiring image for the pediatric dental patient | 147 |
| 13.5 Abbreviations | 150 |

13. Appendices

13.1 Recommended X-ray Exposure Table

A. PANO

Standard / TMJ / Sinus

| Gender / Figure | Hard (kVp / mA) | Normal (kVp / mA) | Soft (kVp / mA) |
|-----------------|-----------------|-------------------|-----------------|
| Man | 75 / 12 | 74 / 12 | 73 / 12 |
| Woman | 74 / 12 | 73 / 12 | 72 / 12 |
| Child | 68 / 10 | 67 / 10 | 66 / 10 |

[Fast Mode]

| Gender / Figure | Hard (kVp / mA) | Normal (kVp / mA) | Soft (kVp / mA) |
|-----------------|-----------------|-------------------|-----------------|
| Man | 75 / 14 | 74 / 14 | 73 / 14 |
| Woman | 74 / 14 | 73 / 14 | 72 / 14 |
| Child | 68 / 12 | 67 / 12 | 66 / 12 |

* Tube voltage and current variation range in the PANORAMIC mode (recommended): 50 ~ 80 kVp, 4 ~ 14 mA

B. CEPH (Scan)

Lateral / Full Lateral

| Figure Gender | Hard (kVp / mA) | Normal (kVp / mA) | Soft (kVp / mA) |
|------------------|-----------------|-------------------|-----------------|
| Man | 87/10 | 85/10 | 83/10 |
| Woman | 85/10 | 83/10 | 81/10 |
| Child | 82/10 | 80/10 | 78/10 |

13. Appendices

PA

| Figure Gender | Hard (kVp / mA) | Normal (kVp / mA) | Soft (kVp / mA) |
|------------------|-----------------|-------------------|-----------------|
| Man | 88/10 | 87/10 | 86/10 |
| Woman | 88/10 | 86/10 | 84/10 |
| Child | 85/10 | 83/10 | 80/10 |

SMV / Waters View

| Figure Gender | Hard (kVp / mA) | Normal (kVp / mA) | Soft (kVp / mA) |
|------------------|-----------------|-------------------|-----------------|
| Man | 90/10 | 88/10 | 86/10 |
| Woman | 88/10 | 86/10 | 84/10 |
| Child | 85/10 | 83/10 | 80/10 |

CARPUS

| Figure Gender | Hard (kVp / mA) | Normal (kVp / mA) | Soft (kVp / mA) |
|------------------|-----------------|-------------------|-----------------|
| Man | 60/6 | 60/5 | 60/4 |
| Woman | 60/6 | 60/5 | 60/4 |
| Child | 60/6 | 60/5 | 60/4 |

* Tube voltage and current variation range in the CEPHALOMETRIC mode (recommended)

13. Appendices

: 60 ~ 90 kVp, 4 ~ 12 mA

C. CBCT

| Mode | | Low Dose | | Ultra Low Dose | |
|-------|--------|----------|-----|----------------|-----|
| | | kVp | mA | kVp | mA |
| Man | Hard | 95 | 8.7 | 80 | 5.0 |
| | Normal | 94 | 8.7 | 79 | 5.0 |
| | Soft | 93 | 8.7 | 78 | 5.0 |
| Woman | Hard | 95 | 8.4 | 80 | 4.7 |
| | Normal | 94 | 8.4 | 79 | 4.7 |
| | Soft | 93 | 8.4 | 78 | 4.7 |
| Child | Hard | 95 | 8.4 | 80 | 4.7 |
| | Normal | 94 | 8.4 | 79 | 4.7 |
| | Soft | 93 | 8.4 | 78 | 4.7 |

Depending on the circumference of the patient's head, X-ray intensity may be classified as Hard, Normal, or Soft :

Soft ≤ Normal ≤ Hard



| Age Group | Average head circumference | Range (cm) | Classification of head circumference |
|-----------|----------------------------|------------|--------------------------------------|
| Child | 53±3 cm | > 53±3 | Hard |
| | | 53±3 | Normal |
| | | 53±3 < | Soft |
| Adult | 56±3 cm | > 56±3 | Hard |
| | | 56±3 | Normal |
| | | 56±3 < | Soft |

13. Appendices



- Maximally allowed tube voltage / current: $kVp \pm 10 \% / mA \pm 20 \%$ according to IEC60601-2-7.
 - Due to image optimization performed prior to shipping, equipment data may differ slightly from those specified in the table.
-

13. Appendices

13.2 X-ray Dose Data

The X-ray dose data is extracted from the X-ray Dose Test Report for the PaX-i3D Smart.

X-ray Dose Test Report for the PaX-i3D Smart maintains dosemetric evaluation of VATECH dental diagnostic system meets all requirements specified in the IEC Collateral Standard. To limit unnecessary exposure to the patient, operator or other staff, the PaX-i3D Smart is designed to comply with IEC 60601-1-3 Part 1 General Requirements for Safety.

| Test Condition | |
|---------------------------|--|
| Brand Name (Model) | PaX-i3D Smart(PHT-30LFO) |
| Sensor type | PANO/CBCT: Xmaru 1404CF CEPH: Xmaru 2301CF(Scan Type) |
| X-ray generator | DG-07C11T2 |

13. Appendices

13.2.1 DAP Table

| Test Equipment | | | |
|----------------|--------------|-------|--------------|
| Instrument | Manufacturer | Model | S/N |
| Dose Meter | Piranha | 255 | CB2-08050121 |

| Mode Tested: PANO Normal Adult 13.5s | | | | | | | | |
|--------------------------------------|-------|--------------------------|-------|--------------------------|-------|--------------------------|-------|--------------------------|
| kVp \ mA | 4 | | 6 | | 8 | | 10 | |
| | [mGy] | [mGy · cm ²] | [mGy] | [mGy · cm ²] | [mGy] | [mGy · cm ²] | [mGy] | [mGy · cm ²] |
| 60 | 3.9 | 25.1 | 5.5 | 36.0 | 7.2 | 46.7 | 8.7 | 56.5 |
| 70 | 5.0 | 32.3 | 7.2 | 47.1 | 9.2 | 59.9 | 11.1 | 72.3 |
| 80 | 6.6 | 42.7 | 9.5 | 61.5 | 11.8 | 76.4 | 15.0 | 97.7 |
| 90 | 8.0 | 52.3 | 11.6 | 75.3 | 14.4 | 93.7 | 16.9 | 110.1 |

| Mode Tested: CEPH PA & LAT, 12.9s | | | | | | | | |
|-----------------------------------|-------|--------------------------|-------|--------------------------|-------|--------------------------|-------|--------------------------|
| kVp \ mA | 4 | | 6 | | 8 | | 10 | |
| | [mGy] | [mGy · cm ²] | [mGy] | [mGy · cm ²] | [mGy] | [mGy · cm ²] | [mGy] | [mGy · cm ²] |
| 60 | 0.4 | 4.4 | 0.5 | 6.4 | 0.7 | 8.6 | 0.9 | 10.6 |
| 70 | 0.5 | 5.7 | 0.7 | 8.4 | 0.9 | 11.1 | 1.2 | 13.9 |
| 80 | 0.6 | 7.1 | 0.9 | 10.4 | 1.2 | 13.9 | 1.5 | 17.5 |
| 90 | 0.8 | 9.6 | 1.2 | 14.0 | 1.6 | 18.8 | 2.0 | 23.6 |

| Mode Tested: CBCT (FOV 100x85), 16.4s | | | | | | | | |
|---------------------------------------|-------|--------------------------|-------|--------------------------|-------|--------------------------|-------|--------------------------|
| kVp \ mA | 4 | | 6 | | 8 | | 10 | |
| | [mGy] | [mGy · cm ²] | [mGy] | [mGy · cm ²] | [mGy] | [mGy · cm ²] | [mGy] | [mGy · cm ²] |
| 60 | 2.1 | 106.4 | 3.2 | 157.8 | 4.2 | 209.2 | 5.1 | 256.0 |
| 70 | 3.2 | 156.9 | 4.6 | 229.1 | 6.1 | 305.8 | 7.7 | 382.6 |
| 80 | 4.3 | 213.9 | 6.3 | 316.6 | 8.4 | 419.0 | 10.5 | 523.7 |
| 90 | 5.5 | 275.1 | 8.2 | 409.5 | 10.9 | 543.9 | 13.5 | 677.0 |

13. Appendices

13.2.2 X-ray Leakage Dose

| Test Equipment Information | | | |
|------------------------------|--------------|-------|---------------|
| Instrument | Manufacturer | Model | S/N |
| Radiation Monitor Controller | Radcal | 9015 | 91-1470/19069 |

Test Condition

| Test mode | Detector | kVP | mA | sec |
|-------------------|--------------|-----|----|------|
| PANO / Adult | Xmaru 1404CF | 95 | 16 | 13.5 |
| CEPH / 12x10(in.) | 1210SGA | 90 | 10 | 1.2 |
| CBCT / 10x8.5(cm) | Xmaru 1404CF | 99 | 10 | 18 |

| Direction [°] | Mode | PANO / Adult | CEPH / 12x10(in.) | CBCT / 10x8.5(cm) |
|---------------|---------|--------------|-------------------|-------------------|
| | [mR/hr] | | | |
| 0 | | 5 | 10 | 8 |
| 45 | | 9 | 13 | 7 |
| 90 | | 12 | 12 | 22 |
| 100 | | 11 | 39 | 11 |
| 110 | | 9 | 21 | 9 |
| 120 | | 8 | 22 | 8 |
| 130 | | 15 | 14 | 9 |
| 140 | | 12 | 7 | 12 |
| 150 | | 15 | 1 | 15 |
| 160 | | 12 | 2 | 12 |
| 170 | | 5 | 12 | 5 |
| 180 | | 14 | 19 | 21 |
| 190 | | 3 | 15 | 3 |
| 200 | | 5 | 10 | 5 |
| 210 | | 12 | 30 | 12 |
| 220 | | 6 | 14 | 14 |
| 230 | | 4 | 19 | 4 |
| 240 | | 9 | 28 | 9 |
| 250 | | 5 | 21 | 5 |
| 260 | | 8 | 31 | 8 |

13. Appendices

| | | | |
|-----|----|----|----|
| 270 | 10 | 26 | 10 |
| 315 | 11 | 7 | 11 |

13. Appendices

13.2.3 X-ray Scatter Dose

| Test Equipment Information | | | |
|------------------------------|--------------|-------|---------------|
| Instrument | Manufacturer | Model | S/N |
| Radiation Monitor Controller | Radcal | 9015 | 91-1470/19069 |

PANO Mode

| Mode Tested: PANO Normal Adult 13.5s | |
|--------------------------------------|---------|
| Mode Tested | PANO HD |
| Applied Tube Voltage Peak [kVp] | 90 |
| Applied Tube Current [mA] | 14 |

| Direction [°] | Mode | PANO Normal Adult 13.5s [mR/hr] | | |
|---------------|------|---------------------------------|----------------|--------------|
| | | 1 m (3.3 ft) | 1.5 m (4.9 ft) | 2 m (6.6 ft) |
| 0 | | 0.09 | 0.07 | 0.05 |
| 45 | | 0.09 | 0.07 | 0.05 |
| 90 | | 0.08 | 0.07 | 0.06 |
| 135 | | 0.40 | 0.21 | 0.11 |
| 180 | | 0.46 | 0.20 | 0.09 |
| 225 | | 0.31 | 0.21 | 0.14 |
| 270 | | 0.24 | 0.13 | 0.07 |
| 315 | | 0.10 | 0.09 | 0.07 |
| Bottom | | 0.04 (1 m from Phantom) | | |
| Up | | 0.01 (1 m from Phantom) | | |

13. Appendices

CBCT Mode

| Test Condition | |
|---------------------------------|----------------------------------|
| Tested Mode | CBCT FOV 100 x 85 16.4s Low Dose |
| Applied Tube Voltage Peak [kVp] | 95 |
| Applied Tube Current [mA] | 6.4 |

| Direction [°] | Mode | Ultra Low Dose, FOV 100 x 85 16.4s [mR/hr] | | |
|---------------|------|--|----------------|--------------|
| | | 1 m (3.3 ft) | 1.5 m (4.9 ft) | 2 m (6.6 ft) |
| 0 | | 1.42 | 0.64 | 0.26 |
| 45 | | 1.51 | 0.84 | 0.44 |
| 90 | | 0.05 | 0.03 | 0.01 |
| 135 | | 2.24 | 0.88 | 0.31 |
| 180 | | 2.24 | 0.83 | 0.27 |
| 225 | | 2.29 | 0.87 | 0.29 |
| 270 | | 2.28 | 0.89 | 0.31 |
| 315 | | 1.08 | 0.52 | 0.23 |
| Bottom | | 0.53 (1 m from Phantom) | | |
| Up | | 0.03 (1 m from Phantom) | | |

13. Appendices

13.3 Electromagnetic Compatibility (EMC) Information

Guidance and manufacturer's declaration - electromagnetic emissions.

The Computed Tomography X-ray System PHT-30LFO is intended for use in the electromagnetic environment specified below. The customer or the user of the Computed Tomography X-ray System PHT-30LFO should assure that it is used in such an environment.

| Emissions test | Compliance | Electromagnetic environment |
|--|------------|---|
| RF emissions EN 55011 | Group 1 | The PHT-30LFO uses RF energy only for its internal function. Therefore, its RF emissions are very low and are not likely to cause any interference in nearby electronic equipment. |
| RF emissions EN 55011 | Class A | The PHT-30LFO is suitable for use in all establishments other than domestic, and may be used in domestic establishments and those directly connected to the public low-voltage power supply network that supplies buildings used for domestic purposes, provided the following warning is heeded: |
| Harmonic emissions EN 61000-3-2 | Class A | |
| Voltage fluctuations / flicker emissions EN 61000-3-3 | Complies | Warning: This equipment/system is intended for use by healthcare professionals only. This equipment/system may cause radio interference or may disrupt the operation of nearby equipment. It may be necessary to take mitigation measures, such as re-orienting or relocating the PHT-30LFO or shielding the location. |

13. Appendices

Guidance and manufacturer's declaration - electromagnetic immunity

The Computed Tomography X-ray System PHT-30LFO is intended for use in the electromagnetic environment specified below. The customer or the user of the Computed Tomography X-ray System PHT-30LFO should assure that it is used in such an environment.

| IMMUNITY test | IEC 60601 test level | Compliance level | Electromagnetic environment |
|---|---|----------------------------|--|
| Electrostatic discharge (ESD) EN 61000-4-2 | ±6 kV Contact ±8 kV air | EN 60601-1-2 Test level | Floors should be wood, concrete or ceramic tile. If floors are covered with synthetic material, the relative humidity should be at least 30 %. |
| Electrical fast transient/burst EN 61000-4-4 | ±2 kV for power supply lines ±1 kV for input/output lines | EN 60601-1-2 Test level | Mains power quality should be that of a typical commercial or hospital environment. |
| Surge EN 61000-4-5 | ±1 kV line(s) to line(s) ±2 kV line(s) to earth | EN 60601-1-2 Test level | Mains power quality should be that of a typical commercial or hospital environment. |
| Voltage dips, short interruptions and voltage variations on power supply input lines EN 61000-4-11 | < 5 % UT for 0.5 cycle 40 % UT for 5, 6 cycles 70 % UT for 25, 30 cycles <5 % UT for 5 s | EN 60601-1-2 Test level | Mains power quality should be that of a typical commercial or hospital environment. If the user of the PHT-30LFO requires continued operation during power mains interruptions, it is recommended that the PHT-30LFO be powered from an uninterruptible power supply or a battery. |
| Power frequency (50/60 Hz) magnetic field EN 61000-4-8 | 3 A/m | EN 60601-1-2 Test level | Power frequency magnetic fields should be at levels characteristic of a typical location in a typical commercial or hospital environment. |

NOTE) UT is the a.c. mains voltage prior to application of the test level.

13. Appendices

Guidance and manufacturer's declaration - electromagnetic immunity

The Computed Tomography X-ray System PHT-30LFO is intended for use in the electromagnetic environment specified below. The customer or the user of the Computed Tomography X-ray System PHT-30LFO should assure that it is used in such an environment.

| IMMUNITY test | IEC 60601 test level | Compliance level | Electromagnetic environment |
|------------------------------|-----------------------------|------------------|--|
| Conducted RF EN 61000-4-6 | 3 Vrms 150 kHz to 80 MHz | 3 V rms | <p>Portable and mobile RF communications equipment should be used no closer to any part of the PHT-30LFO, including cables, than the recommended separation distance calculated from the equation applicable to the frequency of the transmitter.</p> <p>Recommended separation distance</p> $d = \left[\frac{3.5}{3} \right] \sqrt{P}$ $d = \left[\frac{3.5}{3} \right] \sqrt{P}$ <p>80 MHz to 800 MHz</p> $d = \left[\frac{7}{3} \right] \sqrt{P}$ <p>800 MHz to 2,5 MHz</p> <p>where P is the maximum output power rating of the transmitter in watts (W) according to the transmitter manufacturer and d is the recommended separation distance in meters (m).</p> <p>Field strengths from fixed RF transmitters, as determined by an electromagnetic site survey, a should be less than the compliance level in each frequency range. b</p> <p>Interference may occur in the vicinity of equipment marked with the following symbol:</p>  |
| Radiated RF EN 61000-4-3 | 3 V/m 80 MHz to 2,5 GHz | 3 V/m | |

NOTE 1) At 80 MHz and 800 MHz, the higher frequency range applies.

NOTE 2) These guidelines may not apply in all situations. Electromagnetic propagation is affected by absorption and reflection from structures, objects and people.

13. Appendices

a Field strengths from fixed transmitters, such as base stations for radio (cellular/cordless) telephones and land mobile radios, amateur radio, AM and FM radio broadcast and TV broadcast cannot be predicted theoretically with accuracy. To assess the electromagnetic environment due to fixed RF transmitters, an electromagnetic site survey should be considered. If the measured field strength in the location in which the PHT-30LFO is used exceeds the applicable RF compliance level above, the PHT-30LFO should be observed to verify normal operation. If abnormal performance is observed, additional measures may be necessary, such as re-orienting or relocating the PHT-30LFO.

b Over the frequency range 150 kHz to 80 MHz, field strengths should be less than 3 V/m.

13. Appendices

Recommended separation distances between portable and mobile RF communications equipment and the PHT-30LFO

The Computed Tomography X-ray System PHT-30LFO is intended for use in an electromagnetic environment in which radiated RF disturbances are controlled. The customer or the user of the Computed Tomography X-ray System PHT-30LFO can help prevent electromagnetic interference by maintaining a minimum distance between portable and mobile RF communications equipment (transmitters) and the Computed Tomography X-ray System PHT-30LFO as recommended below, according to the maximum output power of the communications equipment.

| Rated maximum output power of transmitter W | Separation distance according to frequency of transmitter m | | |
|--|--|--|---|
| | 150 kHz to 80 MHz $d = [\frac{3.5}{3}] \sqrt{P}$ | 80 MHz to 800 MHz $d = [\frac{3.5}{3}] \sqrt{P}$ | 800 MHz to 2,5 GHz $d = [\frac{7}{3}] \sqrt{P}$ |
| 0,01 | 0.12 | 0.12 | 0.23 |
| 0,1 | 0.38 | 0.38 | 0.73 |
| 1 | 1.2 | 1.2 | 2.3 |
| 10 | 3.8 | 3.8 | 7.3 |
| 100 | 12 | 12 | 23 |

For transmitters rated at a maximum output power not listed above, the recommended separation distance d in metres (m) can be estimated using the equation applicable to the frequency of the transmitter, where P is the maximum output power rating of the transmitter in watts (W) according to the transmitter manufacturer.

NOTE 1) At 80 MHz and 800 MHz, the higher frequency range applies.

NOTE 2) These guidelines may not apply in all situations. Electromagnetic propagation is affected by absorption and reflection from structures, objects and people.

13.4 Acquiring image for the pediatric dental patient

13.4.1 Age group: classification table

Ages are classified loosely into the following correspondence between FDA definition and one used in this manual.

| Age Group | FDA | VATECH's Standard |
|------------|----------------------|-------------------|
| Infant | 1 month to 2 years | n/a |
| Child | 2 ~ 12 years of age | Child |
| Adolescent | 12 ~16 years of age | Adult |
| Other | 16 ~ 21 years of age | |
| Adult | > 21 years of age | |

13.4.2 Positioning the pediatric dental patient

Use a cotton roll to fill in missing primary teeth or partially erupted permanent teeth. Adapt adult recommendation for direction of laser light beam guide for use with primary teeth. Observe laser light beam guide on both the right and left sides.

1. Use laser light beam guide to locate mid sagittal plane. Direct patient focus to mirror reflection. Affix decal to mirror to aid patient in maintaining the correct position throughout exposure.
2. Move chinrest into a position that is slightly higher than the patient's chin height before requesting that the patient place chin onto the rest. Direct the patient to assume a position that resembles the erect stance of a soldier.
3. Direct the patient to stick out the chest while dropping the chin down. While holding the unit handles for stability, direct the patient to take a half step in toward the vertical column of the X-Ray device into a position that feels as if he/she is slightly leaning backward.
4. Direct the patient to the lips closed around the bite block during the exposure.
5. Direct the patient to swallow and note the flat position of the tongue. Request that

13. Appendices

the patient suck in the cheeks, pushing the tongue into the correct flat position against the palate and maintain this position throughout the exposure.

<How to product error-free radiographic images for the pediatric patient>

<http://www.dimensionsofdentalthygiene.com/print.aspx?id=3612>

- By Evelyn M. Thomson, BSDH, MS

Panoramic radiographs are often recommended for assessing growth and development of the pediatric patient and for evaluation of developing third molars during adolescence.¹⁻³ While the panoramic technique seems relatively straight forward, producing a diagnostic quality image of the pediatric patient requires a mastery of technical skill.⁴ Modern panoramic x-ray equipment is designed for ease of use, yet studies continue to demonstrate a high incidence of errors.⁵⁻⁷ Positioning errors may occur at an even higher rate in pediatric panoramic radiographs.⁷ The goal of the dental hygienist is to maximize the use of panoramic imagery in the assessment of the pediatric patient, while minimizing the occurrence of retakes that result from radiographic error.

Producing A Quality Panoramic Image

A quality panoramic radiograph should image all of the teeth, erupted and unerupted, in both the maxillary and mandibular arches from condyle to condyle in the horizontal dimension, and from the superior third of the orbit in the superior region to the inferior border of the mandible in the inferior region.^{8,9} The arches should appear straight or slightly U-shaped with the occlusal plane parallel to the horizontal edges of the film **(Figure 1)**. The anterior teeth must not be magnified or diminished in size and overlapping of adjacent posterior teeth should be kept to a minimum.



Figure 1: Example of a diagnostically acceptable panoramic radiograph of an adolescent patient undergoing orthodontic intervention. (Courtesy of Jamie Mace and Will Wright of Schick Technologies Inc.)

The most important component in producing a diagnostically acceptable panoramic image is the patient positioning. All panoramic x-ray machines have guidelines to assist with positioning the dental arches within the three dimensions of the focal trough, an area where the anatomical structures will be imaged in relative clarity. Most panoramic x-ray machines have a bite block to indicate the correct anterior-posterior position or how far forward or back the patient should be positioned, side positioner guides for

13. Appendices

determining the correct lateral alignment, and a chin rest to correctly locate the superior-inferior dimension or how far up or down the chin should be positioned.^{4,10} Panoramic x-ray machines are available with a mirror and laser light beam guide that shines on the patient's face to illustrate various anatomical planes (**Figure 2**). Incorrectly positioning the patient in any of these three dimensions will produce unique and distinct radiographic image errors (**Table 1**).



Figure 2: Laser light beam guides that assist with determining correct patient positioning.

Table 1. Common Panoramic Positioning Errors

| Error | Cause | Corrective action | Tips for pediatric patients |
|---|---------------------------------------|--|--|
| Anterior teeth narrow Severe posterior overlap Vertebrae superimposed over condyles | Archers positioned too far anterior | Position anterior teeth in appropriate position on bite guide. Locate appropriate position with anterior laser light guide. | Use a cotton roll to fill in missing primary teeth or partially erupted permanent teeth. Adapt adult recommendation for direction of laser light beam guide for use with primary teeth. Observe laser light beam guide on both the right and left sides. |
| Anterior teeth wide, blurred out of image Condyles not imaged | Archers positioned too far posterior | Position the midhagittal plane perpendicular to the floor. | Use laser light beam guide to locate midhagittal plane. Direct patient focus to mirror reflection. Alpha dental to mirror to aid patient in maintaining the correct position throughout exposure. |
| Teeth on the right side appear narrowed, severely overlapped. Teeth on the left side appear broad, poorly defined Condyles asymmetrical in width and height | Archers tipped or tilted to the right | | |
| Teeth on the left side appear narrowed, severely overlapped Teeth on the right side appear broad and poorly defined Condyles asymmetrical in width and height | Archers tipped or tilted to the left | | |
| Flat, downward-famed, "brown" appearance to the occlusal plane Palate appears as a widened, thick, dense radiopacity Condyles flare out off the edges of the image Anterior teeth appear wide, elongated | Archers positioned too far superior | Position the Frankfort or the cantomeatal plane parallel to the floor, or the ala-tragus line 5° down toward the floor. | Move chin rest into a position that is slightly higher than the patient's chin before requesting that the patient place chin into the rest. Direct the patient to assume a position that resembles the erect stance of a soldier. |
| Exaggerated upward curve of the occlusal plane creating a "smile" appearance Hyoid bone superimposed over the mandible Condyles tilt inward Anterior teeth appear narrowed, elongated in the maxilla and shortened in the mandible | Archers positioned too far inferior | | |
| Pyramid-shaped radiopacity superimposed over the anterior teeth | Patient in slumped position | Position the back and neck straight. | Direct the patient to stick out the chest while dropping the chin down. While holding the unit handles for stability, direct the patient to take a half-step in toward the vertical column of the x-ray machine into a position that feels as if he/she is slightly leaning backward. |
| Radiolucent shadow of the commissure superimposed over the teeth, mimicking caries | Lips not closed around bite block | Position the lips around the bite block. | Direct the patient to keep the lips closed around the bite block during the exposure. |
| Radiolucency superimposed over the maxillary teeth apices | Tongue not placed against palate | Position the tongue flat against the roof of the mouth. | Direct the patient to swallow and note the flat position of the tongue. Request that the patient tuck in the cheeks, pushing the tongue into the correct flat position against the palate, and maintain this position throughout the exposure. |

FEBRUARY 2009

Dimensions OF DENTAL HYGIENE

Anterior-Posterior Positioning Error

When the arches are positioned incorrectly in the anterior-posterior direction, distortion or ghosting of the anterior anatomy occurs. Unerupted teeth in the anterior region may not be imaged on the radiograph if positioned outside of the focal trough. It is important to note that an error of only 3 mm to 4 mm in either direction will result in a significantly compromised image.¹¹ When the arches are positioned too far anterior, the anterior teeth will appear narrow and diminished in size. The vertebrae of the spinal column may

13. Appendices

be superimposed over the condyles at the edges of the film and, depending on the size of the child, may be superimposed over the rami of the mandible blocking a clear view of the posterior teeth (Figure 3). When the arches are positioned too far posteriorly, the anterior teeth will appear broad or widened. If the position is excessively posterior, anterior teeth may be completely blurred from the image and the condyles may be cut off from the edges of the film.

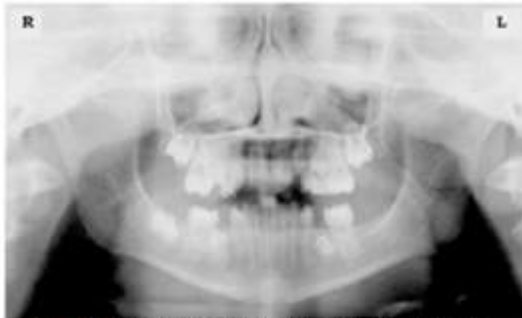

Figure 3: Incorrect position too far anteriorly. Note the narrow anterior teeth and superimposition of the spinal column over the condyles. The radiolucency superior to the maxillary apices indicates that the tongue was not placed against the palate. An open lip line can also be detected.

To avoid these imaging errors, the anterior teeth must occlude edge-to-edge onto the designated area of the bite block. Achieving this position is easily compromised during exfoliation of primary teeth, making precise occlusion difficult when one tooth or multiple teeth are missing or partially erupted. A cotton roll may be attached to the bite block to fill in the space created by the missing tooth or teeth. Additionally, an adjustment may be necessary when using a laser light beam guide. The manufacturer's instructions for directing the laser light beam at a predetermined tooth or interproximal space usually apply to adult patients. These instructions may need to be modified for the pediatric patient with primary or mixed dentition.

Lateral Left-Right Positioning Error

When the arches are positioned incorrectly in the lateral left-right dimension, the posterior teeth on one side will appear broad or widened, while the teeth on the other side will appear narrowed or diminished in width and severely overlapped (**Figure 4**). This image distortion is similar to that which occurs with an incorrect anterior-posterior position. When the arches are rotated or tilted, the posterior teeth on one side move out of the focal trough to a position further away (back) from the image receptor, while the opposite side simultaneously moves closer (forward) to the image receptor. Depending on the severity of rotation or tilting, the inferior border of the mandible will appear distorted and the condyles and rami will appear asymmetrical.



Figure 4: Incorrect lateral position tilted to the right. Note the teeth on the left are wide and poorly defined, while the teeth on the right are narrowed and severely overlapped. The inferior border of the mandible is distorted and the condyles appear asymmetrical.

To avoid imaging errors that result from incorrect lateral positioning, the midsagittal plane must be positioned perpendicular to the floor. Most panoramic x-ray machines have a head positioner and/or laser light beam guide, along with a mirror, to assist in determining the correct lateral head position. The pediatric patient may need additional instructions to maintain the correct position throughout the exposure.

Movement of the tube head during exposure may pique the pediatric patient's curiosity, causing the head to rotate as the eyes follow the movement of the tube head. A vertical line decal affixed to the mirror can serve as a visual aid and a focus point. An eye-catching sticker, such as those purchased from a craft store, can be adhered to the mirror in a position that aligns with the midsagittal plane. The patient can be directed to position the head so that the sticker appears at the tip of the nose and to maintain focus on this reflection throughout the exposure. Pediatric patients may find looking at themselves in the mirror entertaining and a fun way to participate in the process.⁹

Superior-Inferior (Up-Down) Positioning Error

Positioning the dental arches within the superior- inferior (up-down) dimension of the focal trough can be difficult to achieve, especially with children whose smaller size reduces the distance between the shoulders and the inferior border of the chin. When the arches are positioned incorrectly in the superior-inferior direction, the image exhibits multiple distortions, including increased overlapping in the premolar regions. When the arches are positioned too far up or down, the teeth will simultaneously move into a position that is too far back or too far forward, respectively, out of the focal trough.¹¹

Positioning the arches too far superiorly produces a characteristic “frown” or flat, downward- turned appearance to the occlusal plane (**Figure 5**). The condyles flare out and off the edges of the image and the palate appears as a widened, thick, dense radiopacity. This positioning error results in a widened appearance of the palate and obliterates the apical regions of the maxillary teeth, compromising the images of the unerupted developing dentition. As the maxillary arch tips upward, the anterior teeth tilt backward producing the same widened appearance that results from an incorrect anterior- posterior position. Positioning the arches too far inferior produces

13. Appendices

a characteristic “smile” appearance or upward curve of the occlusal plane, with the condyles tilting inward toward the center of the image (**Figure 6**). Depending on the severity of the downward position, the vertebrae may also curve inward and appear superimposed over the condyles, and the hyoid bone may be superimposed over the mandible blocking a clear view of the erupted and unerupted mandibular teeth.

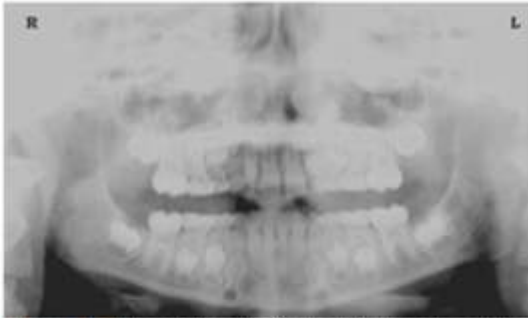

Figure 5: Chin positioned too far up. Note the characteristic “frown” or flat, downward-turned appearance to the occlusal plane. The widened palate obscures the view of the maxillary apices and the developing permanent dentition.

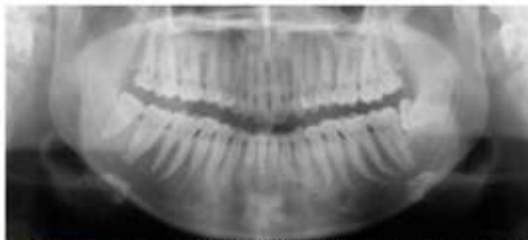

Figure 6: Chin positioned too far down. Note the characteristic “smile” or upward curved appearance to the occlusal plane and the hyoid bone superimposed over the mandible.

Correct positioning of the arches in the superior-inferior dimension requires that the patient stand with erect posture while tucking the chin in and down slightly, a direction that both adults and pediatric patients often find difficult to follow without specific guidance. The result is often a slumped position with the patient hunching the neck and shoulders over in an attempt to place the chin on the chin rest. The vertebrae collapse causing attenuation of the x-ray beam that produces a triangular radiopacity superimposed over the mandible, and if severe, over the maxillary anterior regions as well.

Depending on the manufacturer, panoramic x-ray machines direct the operator to position the Frankfort or the canthomeatal plane parallel to the floor, or the ala-tragus line 5° down toward the floor. This is achieved by raising or lowering the chin rest so that the appropriate landmark lines up with indicators on the machine (**Figure 2**). The patient should be directed to stand in front of the panoramic x-ray machine allowing the operator to place the chin rest into a position that is slightly higher than the patient’s chin. The

patient is then requested to move into the overhead assembly of the machine and remain standing tall. If further adjustment is needed, it is usually to a lowered chin position. Once the patient's chin is resting on the chin rest, it is easier to move to a lower position than to a higher one. To assist with placing the chin on the chin rest while maintaining an erect posture, the pediatric patient can be directed to stand like a soldier. Most children are familiar with the straight back, chest forward, tucked chin position demonstrated by military persons, and can readily mimic this stance.

Further Recommendations

Prior to beginning the exposure, the patient should be directed to close the lips around the bite block and to place the tongue against the palate. Leaving the lips open will create a soft tissue shadow across the teeth that that can be mistaken for caries.⁷ Leaving the tongue at rest during the exposure allows the radiation to easily penetrate the empty space of the oral cavity between the dorsal surface of the tongue and the palate, producing a radiolucent shadow that diminishes the diagnostic quality of the radiograph **(Figure 3)**.

“Filling in” this space with the soft tissue of the tongue can increase the quality of the image by diminishing this radiolucent shadow. When directed to place the tongue on the roof of the mouth, the pediatric patient is likely to press only the tip of the tongue against the palate. While an adult patient can usually understand what is required when directed to swallow and note the position of the tongue, a child may be directed to suck in the cheeks, which results in pushing the tongue into a position flat against the palate.⁷

13. Appendices

Conclusion

In addition to these guidelines for producing error-free radiographic images for the pediatric patient, panoramic machines should be evaluated periodically for accuracy. Changes may occur over time to the focal trough that interfere with the diagnostic quality of the machine.⁶ If a decrease in image quality is noted in spite of following accurate patient positioning steps, the panoramic x-ray machine should be inspected and the focal trough recalibrated. The dental hygienist who is skilled in understanding panoramic equipment operation and pediatric patient management is more likely to produce radiographic images that result in higher diagnostic yields.

References

1. *Public Health Service, Food and Drug Administration, American Dental Association Council on Dental Benefit Program, Council on Dental Practice, Council on Scientific Affairs. The Selection of Patients for Dental Radiographic Examinations. Washington, DC: United States Department of Health and Human Services; 1987 (revised 2005):1-23.*
2. *Pinkham PS, Casamassimo, Fields HW, McTigue DJ, Nowak AJ. Pediatric Dentistry Infancy through Adolescence. 4th ed. St. Louis: Elsevier Saunders; 2005:677.*
3. *Thomson EM. Panoramic radiographs and the pediatric patient. Dimensions of Dental Hygiene. 2008;6(2):26-29.*
4. *Rushton VE, Rout J. Panoramic Radiology. London: Quintessence Publishing Co Ltd; 2006:17, 84-85.*
5. *Kullman L, Joseph B. Quality of digital panoramic radiography in a newly established dental school. Swedish Dent Journ. 2006; 30: 165-170.*
6. *Akarslan ZZ, Erten H, Güngör K, et al. Common errors on panoramic radiographs taken in a dental school. J Contemp Dent Pract. 2003;4:24-34.*
7. *Rushton VE, Horner K, Worthington HV. The quality of panoramic radiographs in a sample of general dental practices. Br Dent J. 1999; 26: 630-633.*
8. *White SC, Heslop EW, Hollender LG, Mosier KM, Ruprecht A, Shrouf MK. Parameters of radiologic care: an official report of the American Academy of Oral and Maxillofacial Radiology. Oral Surg Oral Med Oral Pathol. 2001;91:498-511.*
9. *McDonald RE, Avery DR, Dean JA. Dentistry for the Child and Adolescent. 8th ed. St. Louis: Elsevier Mosby; 2000:71-72.*
10. *Johnson ON, Thomson EM. Essentials of Dental Radiography for Dental Assistants and Hygienists. 8th ed. Upper Saddle River, NJ: Prentice Hall 2007:388-397.*
11. *Serman N, Horrell BM, Singer, S. High-quality panoramic radiographs. Tips and tricks. Dentistry Today. 2003;22(1):70-73.*

13.4.3 Setting exposure values to the age group

For more information about this topic, refer to the Appendices 13.1 Recommended X-Ray Exposure Table.

13.4.4 The References Pertinent to the Potential Risks for the Pediatric Patients

1. Literature

- I. ESPELID, I. MEJÅRE, K. WEERHEIJM: EAPD guidelines for use of radiographs in children, P40-48. European Journal of Pediatric Dentistry 1/2003

Guidelines in dental radiology are designed to avoid unnecessary exposure to X-radiation and to identify individuals who may benefit from a radiographic examination. Every prescription of radiographs should be based on an evaluation of the individual patient benefit. Due to the relatively high frequency of caries among 5 year old children it is recommended to consider dental radiography for each child even without any visible caries or restorations. Furthermore, radiography should be considered at 8-9 years of age and then at 12-14, that is 1-2 years after eruption of premolars and second molars. Additional bitewing controls should be based on an overall assessment of the caries activity/risk. The high-risk patient should be examined radiographically annually, while a 2-3 years interval should be considered when caries activity/risk is low. Routine survey by radiographs, except for caries, has not been shown to provide sufficient information to be justified considering the balance between cost (radiation and resources) and benefit.

- MICHAEL L. TAYLOR, B.SC. TOMAS KRON, PH.D., AND RICK D. FRANICH, PH.D: ASSESSMENT OF OUT-OF-FIELD DOSES IN RADIOTHERAPY OF BRAIN LESIONS IN CHILDREN, Int. J. Radiation Oncology Biol. Phys., Vol. -, No. -, pp. 1-7, 2010

To characterize the out-of-field doses in pediatric radiotherapy and to identify simple methods by which out-of-field dose might be minimized, with a view to reducing the risk of secondary cancers Out-of-field doses to pediatric patients can be minimized by using simple treatment

- C. THEODORAKOU, K. HORNER, K. HOWARD, A. WALKER: Pediatric organ and effective doses in dental cone beam computed tomography

Dental CBCT has been associated with higher radiation risk to the patients compared to conventional dental X-Ray imaging. Several studies have investigated the radiation doses involved in dental CBCT for adults but none has looked into pediatric doses. This study estimates the organ and effective doses to two pediatric tissue-equivalent phantoms using thermo luminescent dosimeters for three dental CBCT units and six imaging protocols. The doses to the thyroid, salivary glands and brain ranged from 0.068mSv to 1.131mSv, 0.708mSv to 2.009mSv and 0.031mSv to 1.584mSv respectively. The skin and red bone marrow have received much lower doses than the other three organs. The effective doses ranged from 0.022

13. Appendices

mSv to 0.081 mSv. The effective doses calculated in this study were much higher than those of panoramic X-Ray imaging but lower than conventional CT

- CHIYO YAMAUCHI-KAWAURA & KEISUKE FUJII & TAKAHIKO AOYAMA & SHUJI KOYAMA & MASATO YAMAUCHI: Radiation dose evaluation in head and neck MDCT examinations with a 6-year-old child anthropomorphic phantom, *Pediatr Radiol* (2010) 40:1206–1214 DOI 10.1007/s00247-009-1495-z

Background: CT examinations of the head and neck are the most commonly performed CT studies in children, raising concern about radiation dose and their risks to children.

Objective: The purpose of this study was to clarify radiation dose levels for children of 6 years of age undergoing head and neck multi-detector CT (MDCT) examinations.

Materials and methods: Radiation doses were measured with small-sized siliconphotodiode dosimeters that were implanted at various tissue and organ positions within a standard 6-year-old anthropomorphic phantom. Organ and effective doses of brain CT were evaluated for 19 protocols in nine hospitals on various (2–320 detector rows) MDCT scanners.

Results: The maximum value of mean organ dose in brain CT was 34.3 mGy for brain. Maximum values of mean doses for the radiosensitive lens and thyroid were 32.7 mGy for lens in brain CT and 17.2 mGy for thyroid in neck CT. seventy-fifth percentile of effective dose distribution in brain CT was approximately the same as the diagnostic reference level (DRL) in the 2003 UK survey.

2. Website

For additional information on pediatric X-ray imaging, please refer to the websites below.

- <http://www.fda.gov/radiation-emittingproducts/radiationemittingproductsandprocedures/medicalimaging/ucm298899.htm>
- <http://www.imagegently.org/>

13. Appendices

13.5 Abbreviations

| | |
|--------------|--|
| AC | Alternating Current |
| AF | Auto-Focusing |
| AMPT | Adaptive layer Mode Panoramic Tomography |
| CAN | Controlled Area Network |
| CBCT | Cone-Beam Computed Tomography |
| CMOS | Complementary Metal-Oxide -Semiconductor |
| CT | Computed Tomography |
| DAP | Dose Area Product |
| DC | Direct Current |
| DICOM | Digital Imaging and Communications in Medicine |
| EMC | Electromagnetic Compatibility |
| ENT | Ear, Nose and Throat |
| ESD | ElectroStatic Discharge |
| EUT | Equipment Under Test |
| FDD | Focal spot to Detector Distance |
| FOD | Focal spot to Object Distance |
| FOV | Field of View |
| FPD | Flat Panel Detector |
| IEC | International Electro technical Commission |
| ISO | International Standards Organization |
| LCD | Liquid Crystal Display |
| LED | Light-Emitting Diode |
| MAR | Metal Artifact Reduction |
| MPSO | Multiple Portable Socket-Outlet |
| ODD | Object to Detector Distance |
| PA | Posterior / Anterior |
| RF | Radio Frequency |
| ROI | Region of Interest |

13. Appendices

| | |
|------------|-----------------------------------|
| SID | Source to Image receptor Distance |
| SIP | Signal Input Part |
| SOP | Signal Output Part |
| SMV | Submento-Vertical |
| TMJ | Temporomandibular Joint |
| UHD | Ultra High Definition |

Copyright by © 2018 Vatech®

All rights reserved.

The documentation, brand name and logo used in this manual are copyrighted.

No part of this manual may be reproduced, transmitted, or transcribed without the expressed written permission of the manufacturer.

We reserve the right to make any alterations which may be required due to technical improvement. For the most current information, contact your VATECH representative.

Tel: +82-1588-9510

Email: gcs@vatech.co.kr

Website: www.vatech.co.kr

Headquarters: 13, Samsung 1-ro 2-gil, Hwaseong-si, Gyeonggi-do, Korea

Factory: 13, Samsung 1-ro 2-gil, Hwaseong-si, Gyeonggi-do, Korea



The CE symbol grants this product compliance to the European Directive for Medical Devices 93/42/EEC as amended by 2007/47/EC as a class II b device.



**EC Representative; Vatech Dental Manufacturing Ltd.
Suite 3, Ground Floor, Chancery House, St. Nicholas Way,
Sutton, SM1 1JB UK**

Tel: +44-0208-652-1900, +44-0208-643-7109

Fax: +44-0208-652-1909

PaX-i3D Smart™

Postal Code: 18449
13, Samsung 1-ro 2-gil, Hwaseong-si, Gyeonggi-do, Korea
www.vatech.co.kr

vatech