



**Meyer Intraoral Scanner**  
Designed for patient comfort and timely scan process



**Meyer CAD System**  
Upgradable and robust software to simplify restoration design



**Meyer CAM System**  
Precise and highly efficient five-axis cutting over a broad range of materials



Hefei Meyer Optoelectronic Technology Inc.



**Address(manufacturing site)**  
No.668 Wangjiang West Road, Hefei High&New Tech Zone, Hefei, Anhui, P.R.China



**Mailbox**  
info@meyermedical.com.au



**Website**  
<https://meyermedical.com.au>

The products illustrated in this brochure reflect knowledge at the time of printing. Meyer accepts no liability for any deviations from the illustrations including color, shape, print error or any other errors, and reserves all rights to make changes to the brochure at any time, or to discontinue the products described herein without notice or obligation. Contact local Meyer representative for the most updated information.

© 2021 Hefei Meyer. All rights reserved.



# MEYER CBCT **3D** PRO

Smart all-in-one tailored for professional needs



## All-in-one with upgradability

## Multiple FOV configurations



The Meyer extraoral 3D PRO CBCT system collects complete oral data in one scan and reconstructs all aspects of high-resolution images as needed for accurate clinical diagnostics. The resulting 3D images and analytical data provide essential basis for dental filling, implant and orthodontics.

Acquisition modes include CBCT, Pano, Ceph, Part CT and model scanning.



**FOV12×10cm Wise CBCT**

Covers from lower jawbone to maxillary sinus, and airway.  
Suitable for general and local diagnostics, and preoperative evaluation of dental implant.



**FOV15×10.5cm Honor CBCT**

Covers from lower jawbone to maxillary sinus, TMJ and airway.  
Suitable for complete dentition scan, TMJ examination and preoperative evaluation of dental implant.



**FOV17×11cm Dream CBCT**

Covers from lower jawbone to maxillary sinus, TMJ and airway.  
Suitable for general and high-resolution local diagnostics, TMJ examination and preoperative evaluation of dental implant.



# Robust diagnostic software



## Safeguard with patented hybrid pulsed X-ray technology

The patented hybrid pulsed X-ray source technology enables lower dose radiation, while allows accurate diagnosis with high-definition images. The X-ray dose can be adjusted according to the patient age and physique to minimize radiation exposure.

(Hybrid pulsed X-ray technology and DC X-ray technology are optional)

## MyDent Viewer 3D diagnostic software boost everyday activity

MyDent Viewer 3D diagnostic software implements AI technology through modular design, with functional modules including multiplanar reconstruction, curved surface reconstruction, implant simulation, TMJ modelling, and 3D orthodontic simulation. Functions associated with various modules also include 3D panoramic view, 3D positioning, automatic neural tube labelling, automatic bone density measurements, automatic TMJ positioning, automatic cephalogram reconstruction, 3D airway analysis, etc.

## Precision with safety



### Panoramic

Optimized tomographic scan tracks and HD panoramic images by combined X-Y axes motion and structural rotation, allows for confident diagnosis of both mandible and maxilla regions.

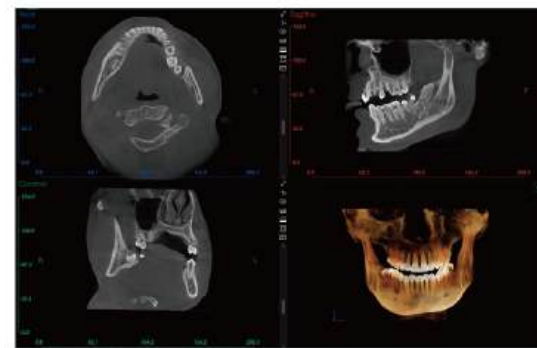

### CBCT

Precise 3D anatomy of human faces and jaws are displayable and reformation on any plane is achievable. Distance, area, volume and profile trace are accurately measured.



### Cephalometric

Dual-level alignment of a single X-ray source to produce HD cephalometric images with low dose radiation.



# Smarter performance smarter practice



## Advanced hardware · Accurate imaging

Our advanced algorithms integrate with advanced hardware technology to achieve higher quality, closer-to-reality images, providing dentists with more accurate clinical information for diagnosis.



## Mass data · Instantaneous image reconstruction AI

With self-built mass data of clinical images, Meyer CBCT overturns the traditional iterative reconstruction algorithm by its AI image reconstruction technology that has greatly enhanced computing capacity. The instantaneously reconstructed mass images have also significantly saved the waiting time.



## AI panoramic AI

The advanced AI+TS technology generates high-definition panoramic images with sufficiently improved image formation rate, and substantially enhances clarity and accuracy of clinical details.



## AI noise reduction AI

The innovatively designed AI+EM technology reduces image noise and distortion, and significantly improves image clarity.

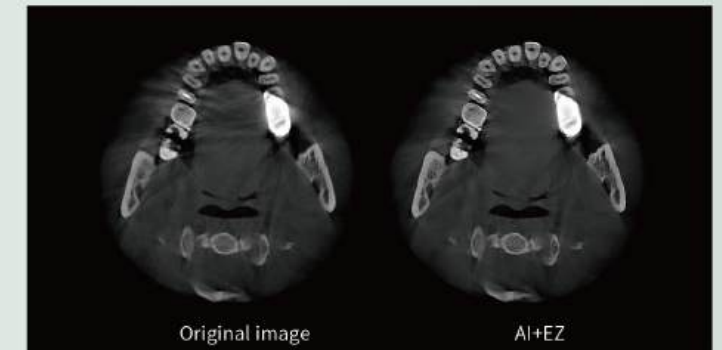

## AI artifact removal AI

The new generation AI+EZ technology effectively removes enamel/metal artifacts, and significantly improves display of structural details.



Scan the code to watch the processing effect



AI panoramic



AI noise reduction



AI artifact removal

# Clinical images

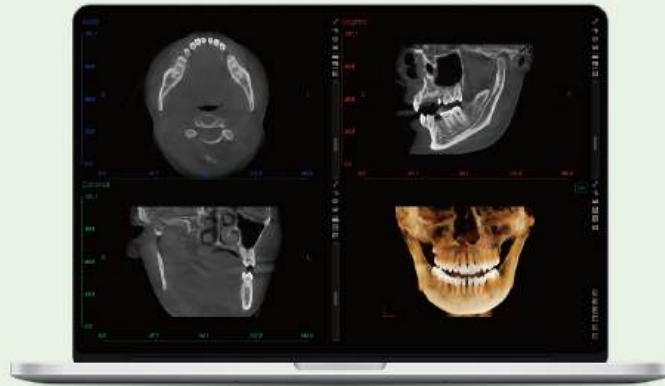

Image of Honor CBCT (FOV 15×10.5cm)



Image of Wise CBCT (FOV 12×10cm)



Image of Dream CBCT (FOV 17×11cm)

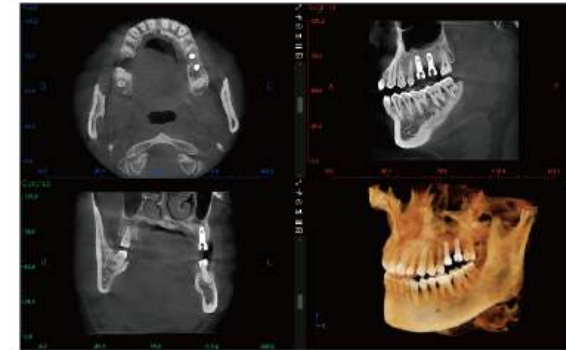

Dental implant — Evaluation of position and shape

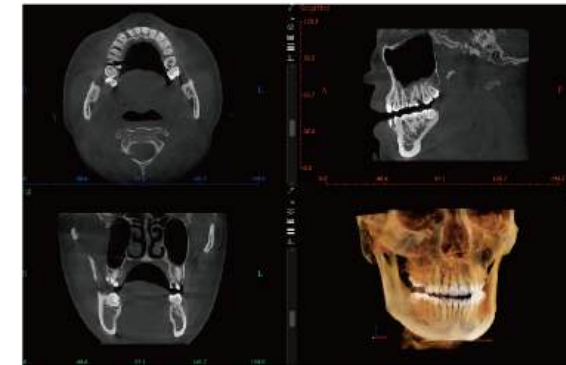

Dental caries

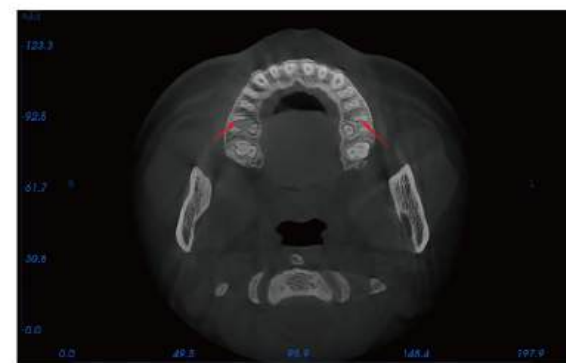

MB2



Orthodontics

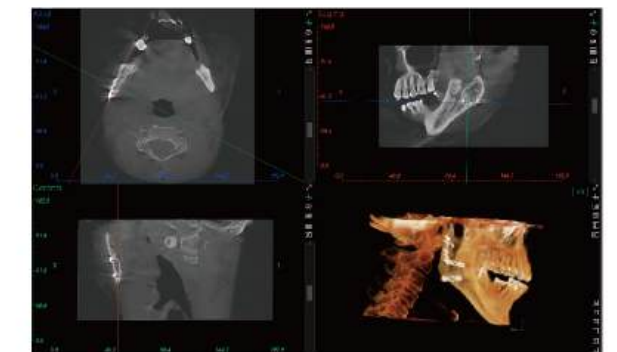

Maxillofacial trauma



TMJ

# Technical specifications

Model	SS-X9010DPro-3DE	SS-X9010DPro-3D
Function	CBCT+Pano+Ceph	CBCT+Pano
Voltage	AC230V±10%	
Tube Model	D-054SB	
Focal Spot	0.5 x 0.5mm	
Total Filtration	5.7mmAL (CT), 2.7mmAL (others)	
Tube Voltage	60~90kV	
Tube Current	2~10mA	
X ray radiation time	CT: 20secs (8.7secs effective irradiation for hybrid pulsed X-ray technology) Pano: 17secs Ceph: 12secs	
Focal spot to skin	250mm	
Net Weight	260KG	220KG
Operating System	Windows 10	

## Equipment dimensions

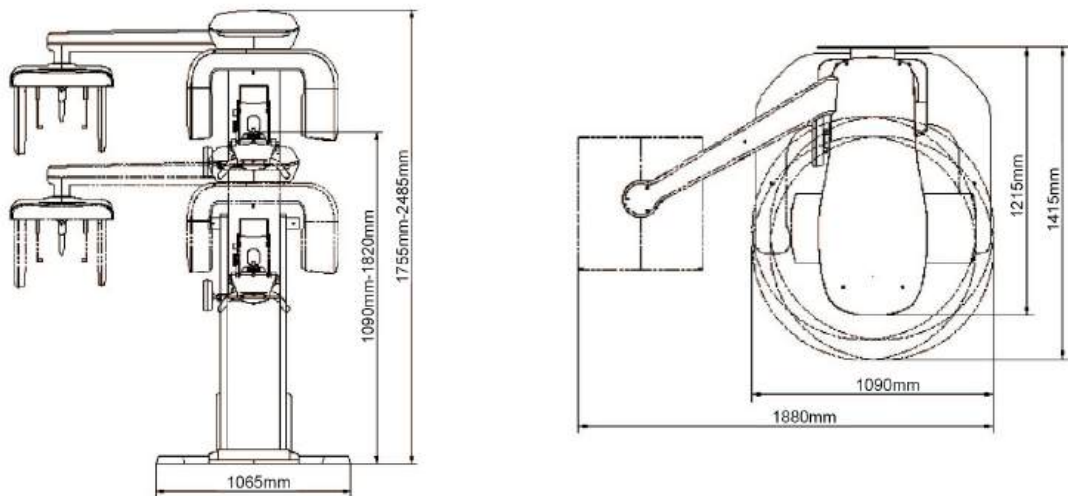

# Green Meyer Green Future

## We comprehensively integrate sustainability into our system

"Green design" in our research process utilises sustainable technology, materials, and crafting to minimise waste generation while maintaining high quality and efficiency. For example, the implementation of 3D printing in designing new products has substantially shortened our research period; the substitution of welding and polishing with bending and riveting is more environmentally friendly.

"Green manufacture" is also part of the intelligent manufacturing system developed by Meyer, including the internalisation of the automated lacquering technique to minimise waste generation, equipment technology upgrade to reduce emission, and increasing application of automation in factories to reduce labour while promoting product stability and consistency.

MEYER